

Project _____

Item Number _____

Quantity _____

PM91 - PM91G



Prep-Mate™ Power Drive Unit

MADE IN THE USA

Models:

- PM91: #12 POWER DRIVE UNIT
- PM91G: #12 POWER DRIVE UNIT WITH EXTENDED LEGS



#12 Hub Power Drive Unit

Features:

- 1 HP motor
- Power base will drive any accessories made for the #12 power take off (PTO) hub.
- Runs attachments at 250rpm.
- On/off switch has removable operator key to prevent unauthorized operation.
- Comes with a 5 inch deep prep container with cover
- PM91G has all the above features but also features extended legs to allow you to use a larger prep container.

Standard Accessories:

- 5" deep prep container with cover.

Optional Accessories

- VS9 vegetable slicer attachment
- VS9H grater/shredder attachment
- ALMFC12 meat and food grinder
- 1000450 plastic cover

Warranty:

- One year, on-site parts and labor

Univex Corporation

Unit is a power drive unit only
see back of spec sheet for the
different optional #12 attachments.



WE RAISE THE BAR. WE SET THE STANDARD.

Prep-Mate™ Power Base

PM91/PM91G

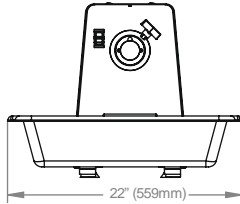

← 10.5" (267mm) →
Width of Just
Power Unit

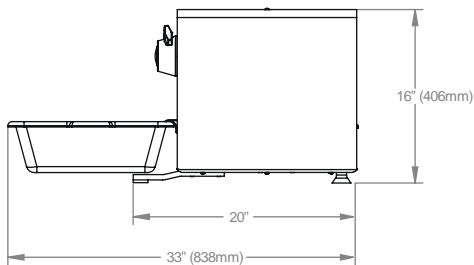
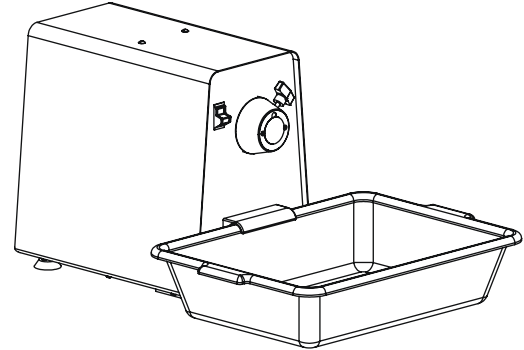

ALMFC12 meat and food grinder

Comes with housing, worm, ring, feed pan, stomper, 3/16" (5mm) plate and X-knife. See spec sheet for more details.



VS9 vegetable slicer attachment

Comes with housing & adjustable "S" knife assembly. Use for slicing carrots, lettuce, cucumbers, celery, and other vegetables.



VS9H grater/shredder attachment

Comes with housing, hub and shaft, and a 3/16" (5mm) shredding plate. Use with cheese, cole slaw, or bread crumbs. See spec sheet for more plate options.

Motor: 1 hp capacitor start, 1740rpm, ball bearing motor with cushioned mounts to reduce vibration & noise.

Drive: 7:1 reduction increases torque, ribbed poly-V belt, 266 rpm drive shaft supported by ball bearings in the PTO housing.

Drive Assembly: Completely enclosed in a powder coat finished 10 gauge steel housing finished steel cover.

Switch: Rocker-type double-pole on/off switch located access from the front or left side of unit. Also features a removable key to stop unauthorized use of machine.

NEMA #: 5-15-P

Electrical Information (60Hz)

	Voltage	Phase	Amps
Standard Voltage	115	1	11.5

Shipping Information

Net Weight	Shipping Weight	Overall Dimensions
82 lbs. (37.2Kg)	92 lbs. (42 Kg)	24"(610mm) H X 19" (483mm) W X 26" (660mm) D



Univex Corporation
www.Univexcorp.com

3 Old Rockingham Rd
Salem, NH 03079
United States of America

TEL: 800.258.6358
INTL TEL: 603.893.6191
FAX: 800.356.5614
INTL FAX: 603.893.1249