



Persons under the age of 18 years are not permitted to operate or have accessibility to operate this equipment per U.S. Department of Labor Employment Standards Administration Fact Sheet No. ESA91-3.

TO INSURE BOTH SAFE AND TROUBLE-FREE PERFORMANCE, WE STRESS THAT ALL PERSONNEL THAT WILL BE INVOLVED WITH YOUR NEW UNIVEX WP-200 WATERMELON PEELER **MUST** READ AND UNDERSTAND THESE INSTRUCTIONS **BEFORE** ATTEMPTING TO OPERATE THIS UNIT.

.....

WE APPRECIATE YOUR COOPERATION AND YOUR BUSINESS.  
SHOULD THERE BE A QUESTION OR IF WE CAN BE OF FURTHER  
ASSISTANCE, PLEASE CALL US  
**1-603-983-6191**

## TABLE OF CONTENTS

DESCRIPTION	PAGE
TABLE OF CONTENTS .....	1
LIST OF ILLUSTRATIONS .....	1
INTRODUCTION .....	2
INSPECTION .....	2
SAFETY INSTRUCTIONS .....	2
INSTALLATION .....	2
ASSEMBLY INSTRUCTIONS .....	4
OPERATOR'S INSTRUCTIONS .....	5
PREPARATION OF MELONS FOR PEELING .....	5
MELON SANITIZING .....	5
PROCESSING PRODUCT .....	5
CLEANING .....	6
SHARPENING THE KNIVES .....	6
WARRANTY .....	BACK COVER

## LIST OF ILLUSTRATIONS

DESCRIPTION	PAGE
FIGURE 1 OVERALL VIEW OF THE WP-100 MELON PEELER .....	3
FIGURE 2 CRANK ASSEMBLY .....	4
FIGURE 3 CENTER HEAD ASSEMBLY .....	4
FIGURE 4 KNIFE ASSEMBLY .....	4

## INTRODUCTION

Thank you for purchasing the Univex Watermelon Peeler. The WP-200 allows you to produce perfectly peeled melon halves in a matter of seconds with minimal handling of the edible fruit.

The WP-200 is designed to process melons up to 11 1/2 inches in diameter and 20 inches long.

The WP-200 is safe and simple to operate, increases the yield of edible fruit over hand peeling methods, is 4 to 8 times faster than hand peeling and it is easy to clean. In addition, reduced handling results in less bruising, thereby extending the shelf life of the peeled fruit.

The finished product of the Watermelon Peeler cannot be duplicated by hand peeling and allows chefs to present their customers with creative presentations of melons not possible before.

## INSPECTION

All Univex WP-200 Watermelon Peelers are inspected prior to packaging to assure the quality of the machine. However, upon unpackaging the machine, all items should be carefully inspected and verified that they are correct. Any damage, imperfection, or shortages should be reported immediately to your dealer or directly to the Univex Customer Service Department, and /or the shipping carrier.

## OPERATOR SAFETY

- Read and understand all instructions and safety warnings prior to operating the WP-200.
- Never put fingers or any utensils in the entry of the peeler or in the knife area of the peeler.
- **CAUTION:** The knives are sharp and can cut fingers; the center head pins are sharp.
- Always fully assemble the machine before using it.

## INSTALLATION

The Univex WP-200 Watermelon Peeler is a table-top unit designed to be mounted and used on a table. Make sure that a comfortable working clearance is provided around the machine for safety and ease of operation and that the machine is installed where it will save the operator steps. Proper location should include space for the melon collection container. Determination of where the WP-200 Watermelon Peeler will be placed during operation should take into consideration, the flow of the whole melons, the placement of the peeled melons and the disposal of the waste skin and seeds.

OVERALL VIEW OF WP-200  
WATERMELON PEELER  
FIGURE 1

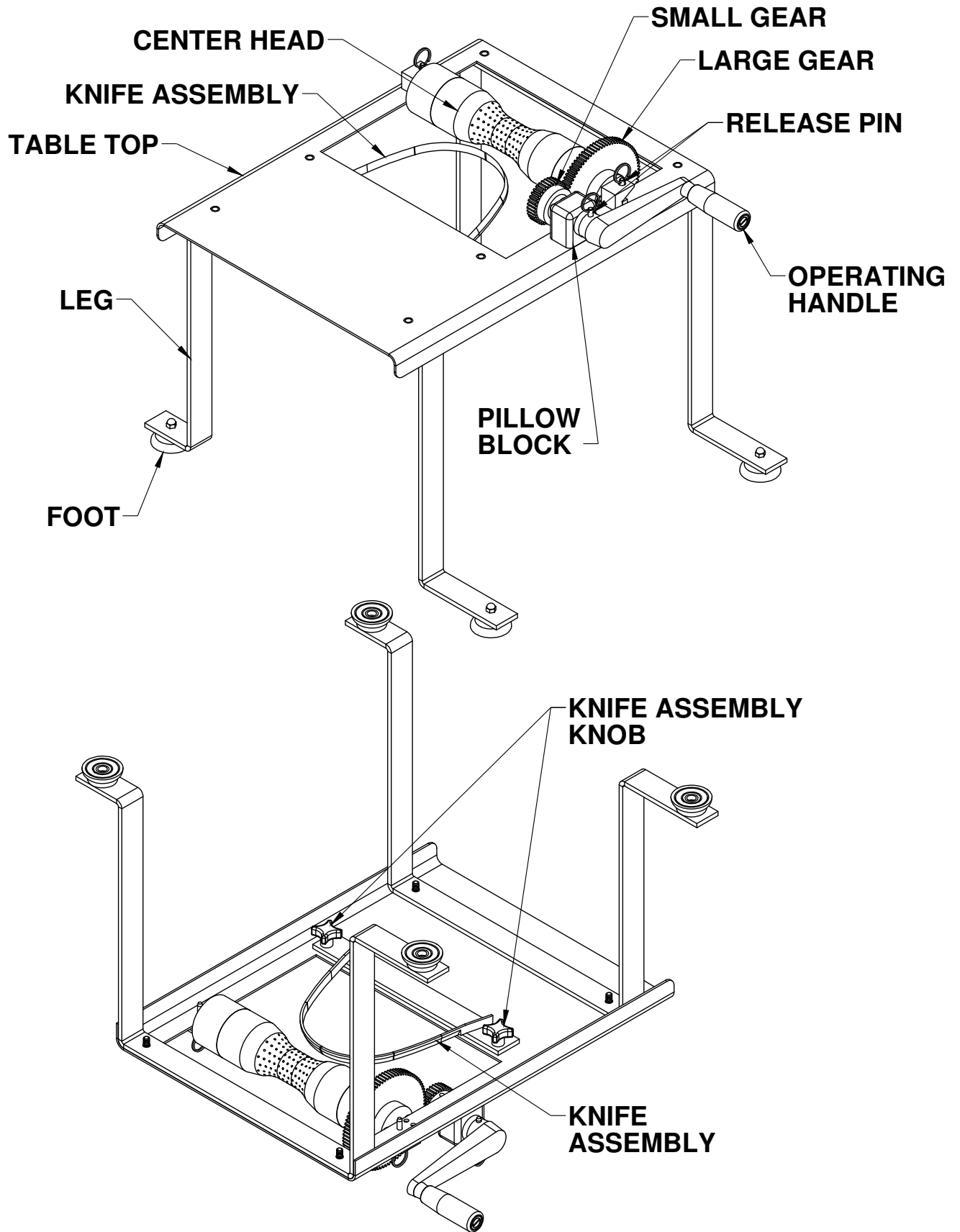

## ASSEMBLY INSTRUCTIONS

Assemble the WP-200 Watermelon Peeler in the following order:

1. Assemble the small gear and shaft through one spacer and the pillow block then the other spacer and into the handle assembly and secure it with the release pin. Refer to the crank assembly figure 2.
2. Slide the center head with the large gear and spacer onto the center head shaft. Place this assembly into the peeler meshing the gear teeth and placing the square ends of the shaft under the shaft supports. Secure the assembly to the shaft supports with the release pins. Refer to the center head assembly figure 3
3. Place the knife assembly under the top plate and onto the studs and install and tighten the knobs securely. Refer to figure 4.
4. Insure all parts are secure and the center head rotates freely when the handle is turned.

**WARNING:** The knife and center head pins are sharp and can cut fingers.

### CRANK ASSEMBLY

FIGURE 2

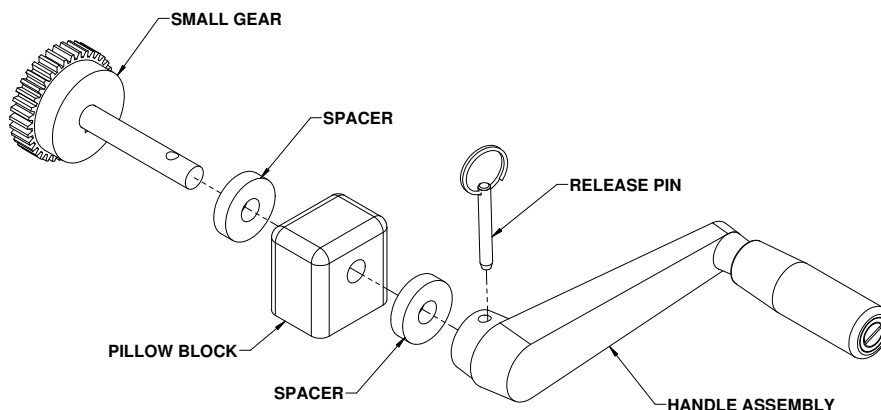

### CENTER HEAD ASSEMBLY

FIGURE 3

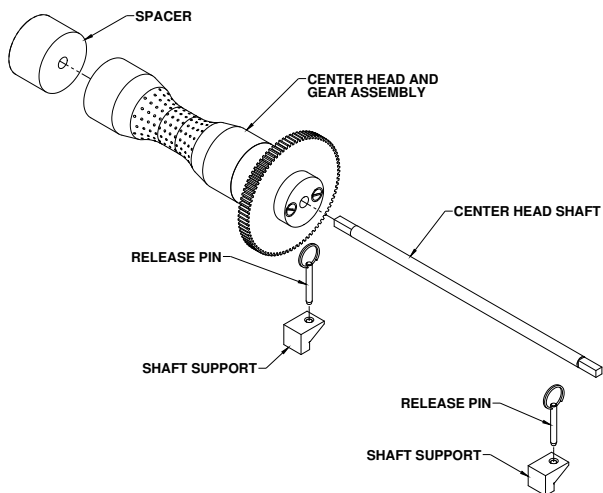

### KNIFE ASSEMBLY

FIGURE 4

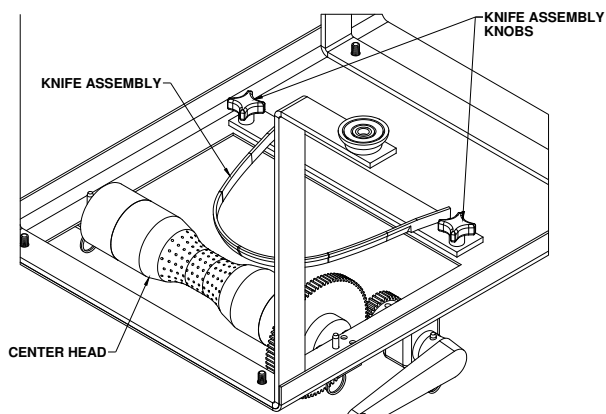

## OPERATOR'S INSTRUCTIONS

### PREPARATION OF MELONS FOR PEELING:

1. **Melon Sanitizing:**

The watermelons should be sanitized on the outside prior to handling and peeling.

2. **Melon Halving:**

Prior to peeling the watermelons with the WP-200, the watermelons must be sliced in half. Carefully slice the watermelons in the long direction of the watermelon. Place the watermelon halves in a convenient location on the worktable beside the peeler.

### PROCESSING PRODUCT:

Make sure the WP-200 is completely assembled and all knobs are tight before operating the watermelon peeler. For first time use see the installation instructions on page 2.

Place a clean tub directly under the WP-200 watermelon peeler to receive the peeled melons.

### Feeding the Watermelon Peeler WP-200:

**WARNING:** Be carefully of the knives and the center head gripping pins. They are sharp and can cut fingers. When used correctly and according to the operating instructions the operators hand will never come near the knives or the pins during normal operation.

Grasp a melon half by its rind and place it cut side down on the top plate of the watermelon Peeler. Orient the watermelon such that the long dimension of the watermelon is parallel to the sides of the WP-200. While holding the watermelon by the end opposite the center head gripping pins, guide the leading edge of the watermelon onto the center head and into a row of gripping pins.

Place your left hand on the back end of the watermelon (opposite the gripping pins) and gently push the watermelon forward while simultaneously turning the crank handle, slowly, away from you (clockwise). Lift and guide the watermelon into the vertical position while continuing to turn the handle. When the straight portion of the watermelon has passed through the knife, shift your left hand under the machine and gently pull the watermelon toward you as you continue to turn the handle with your right hand until the melon has completely passed through the knife.

### **CLEANING:**

A brush is supplied to aid in cleaning the WP-200 Watermelon Peeler. The WP-200 can be cleaned fully assembled, by immersing it in a sink and using the brush and a mild detergent to wash it. Once the WP-200 Peeler has been thoroughly washed, rinse, sanitize and are dry the peeler. The WP-200 Peeler can also be disassembled in the reverse of the assembly instructions and the subassemblies can be washed individually.

**WARNING:** The knives and the center head gripping pins are sharp and can cut fingers. Use extreme caution when handling the knife assemblies or the center head assembly to prevent injury or damage to the knives or pins.

### **SHARPENING:**

The knife edges are designed for years of trouble-free service. In the event the knife edges require sharpening, contact a commercial knife sharpening service or replace the knife.

## *Warranty*

The Univex WP-200 watermelon Peeler is warranted by Univex Corporation against any defects in materials or workmanship for a period of one year from the date of purchase by the end user. Please call the Univex Warranty Service Department at 800-258-6358 to report warranty claims before arranging for repair of the unit. The unit must be delivered to a Univex authorized service agent or to the Univex facility for warranty repairs. The end user is responsible for all shipping or travel charges arising from the repair or servicing of this unit under warranty. Univex will not cover overtime charges of any kind. Any service or repair must take place in the United States.

Damages incurred in transit or incurred because of installation error, accident, alteration or misuse are not covered. Transit damages should be reported to the carrier immediately.

Univex will not be liable for any consequential, compensatory incidental or special damages.

