



ALMFC12 GRINDER ATTACHMENT OPERATOR'S MANUAL



Persons under age 18 are not permitted to operate or have accessibility to operate this equipment per U.S. Dept. Of Labor Employment Standards Administration Fact Sheet No. ESA913.

TO INSURE BOTH SAFE AND TROUBLE-FREE PERFORMANCE WE
STRESS THAT ALL PERSONNEL THAT WILL BE INVOLVED WITH
YOUR NEW UNIVEX MEAT AND FOOD CHOPPER **MUST** READ
AND UNDERSTAND THESE INSTRUCTIONS **BEFORE** ATTEMPTING
TO OPERATE THIS UNIT.



WE APPRECIATE YOUR COOPERATION AND YOUR BUSINESS.
SHOULD THERE BE A QUESTION OR IF WE CAN BE OF FURTHER
ASSISTANCE, PLEASE CALL US.

1-603-893-6191

INTRODUCTION

Please read the following instructions carefully before assembling the ALMFC12 Meat and Food Chopper. This instruction manual contains vital information concerning inspection, safe operation and cleaning of the unit.

INSPECTION

The ALMFC12 Meat and Food Chopper has been inspected and tested at the factory, however, the user should inspect the unit and compare the parts received with the parts list on page 4 prior to use. Any damage should be reported to the carrier immediately and any shortage or deviation of parts should be reported to Univex Corporation.

INSTALLATION

Before attempting to mount the ALMFC12 Meat and Food Chopper to the power source equipment for processing, be sure all equipment is located to save the operator steps and that sufficient clearance is provided all around for safety and ease of operation.

SAFETY

The Univex ALMFC12 Meat and Food Chopper is supplied with a feed pan and a feed stomper. Product to be processed should always be inserted into the chopper housing throat by way of the pan and pressed into the worm with the stomper. **NEVER ATTEMPT TO FEED PRODUCT WITH YOUR FINGERS OR USE ANY UTENSILS OTHER THAN THE STOMPER TO PUSH PRODUCT INTO THE CHOPPER.**

NEVER PUT FINGERS OR OBJECTS INTO THE HOLES IN THE PLATES.

TO AVOID ACCIDENTAL START-UPS, DISCONNECT THE ELECTRICAL POWER TO THE POWER SOURCE EQUIPMENT BEFORE MOUNTING OR DISMOUNTING THE ALMFC12 MEAT AND FOOD CHOPPER.

ALL POWER SOURCE EQUIPMENT IS PROVIDED WITH A THUMB SCREW ON THE POWER TAKE-OFF HOUSING. MAKE SURE THIS THUMB SCREW IS FIRMLY TIGHTENED BEFORE OPERATING THE MEAT AND FOOD CHOPPER.

ALWAYS REMOVE THE MEAT AND FOOD CHOPPER FROM THE POWER SOURCE EQUIPMENT BEFORE CLEANING. NEVER ATTEMPT TO WASH OR RINSE THE MEAT AND FOOD CHOPPER WITH A HOSE IF THE MEAT AND FOOD CHOPPER IS MOUNTED TO THE POWER SOURCE EQUIPMENT. HOSING A MOUNTED MEAT AND FOOD CHOPPER INVITES ELECTRICAL SHOCK.

IT IS A VIOLATION OF UNITED STATES DEPARTMENT OF LABOR REGULATIONS TO PERMIT OPERATION OF THIS UNIT BY ANY PERSON UNDER THE AGE OF 18 YEARS.

ASSEMBLY AND LUBRICATION

Before assembling the ALMFC12 Meat and Food Chopper wash all components thoroughly according to the cleaning instructions below. Lubricate the drive shaft and the fiber washer with a light coat of sanitary Petrol-Gel. Do not lubricate with cooking oil; it becomes gummy. Lubricate the knife and the plate with a light coat of beef tallow.

To assemble the ALMFC12 Meat and Food Chopper:

- Coat the knife and plate with Petrol-Gel.
- Place the knife, **sharp edges facing out**, on the square extension of the worm assembly.
- Place the plate on the pin in the end of the worm and into the chopper housing aligning the notch in the plate with the pin in the chopper housing.
- Screw the ring onto the chopper housing using minimum force. The ring controls the pressure between the knife and the plate. Too much pressure will damage the knife and the plate. Adjusting the ring will not change the consistency of the product, consistency is determined by the plate you use.

Do not run the ALMFC12 Meat and Food Chopper unless it is processing product. The knife and plate are easily ruined by running dry.

WORM ASSEMBLY

FIGURE 1

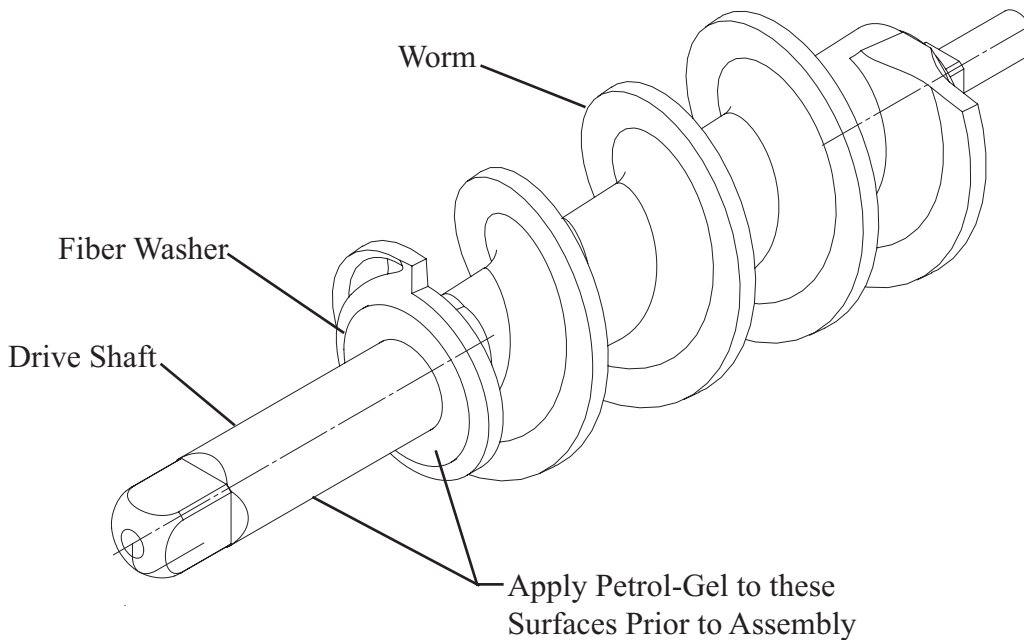

MOUNTING

DISCONNECT THE ELECTRICAL POWER TO THE POWER SOURCE EQUIPMENT BEFORE MOUNTING THE ALMFC12 MEAT AND FOOD CHOPPER.

To mount the ALMFC12 Meat and Food Chopper slide the chopper assembly, without the pan and stomper, into the power take-off hub of the power source equipment. Align the pin in the chopper housing with the hole in the power take-off hub and slide the chopper assembly all the way into the hub. Make sure there is a firm fit between the drive shaft and the mating power take-off adapter provided with the power source equipment. Tighten the thumb screw on the power take-off hub. Fit the pan to the chopper housing and connect the electrical power to the power source equipment.

OPERATING THE ALMFC12 MEAT AND FOOD CHOPPER

- Slice meat into strips, not chunks, which will easily slip down the throat of the chopper housing.
- Place a suitable container at the discharge of the chopper.
- Place the meat in the feed pan and turn the power source equipment on.
- Hand feed the meat into the chopper. **DO NOT** place fingers inside the throat of the chopper, use the stomper to push the meat into the worm.
- If the power source equipment is a food mixing machine, adjust the speed from “1” to a speed that produces the best results.
- Do not use the stomper to force feed the meat into the chopper at an increased rate. Best results are obtained when the meat is fed only as fast as the chopper processes it.
- Switch the power “OFF” when processing is interrupted. Do not run the chopper when it is not processing product.
- When the processing has been completed, switch the power “OFF” and disconnect the power supply cord.

CLEANING

For proper sanitation, dismount and wash the ALMFC12 Meat and Food Chopper immediately after use. Disassemble the components and hand wash them in a warm water and mild soap solution. Handle the knife carefully, **IT IS SHARP AND CAN EASILY CUT FINGERS**. Dry the components with a soft cloth. Store the unit in a refrigerator after cleaning for extra sanitation.

REPAIR

Problems with the ALMFC12 Meat and Food Chopper usually be traced to improper assembly, mounting, dull, worn, or broken parts. Check for solutions in that order.

ALMFC12 MEAT AND FOOD CHOPPER

FIGURE 2

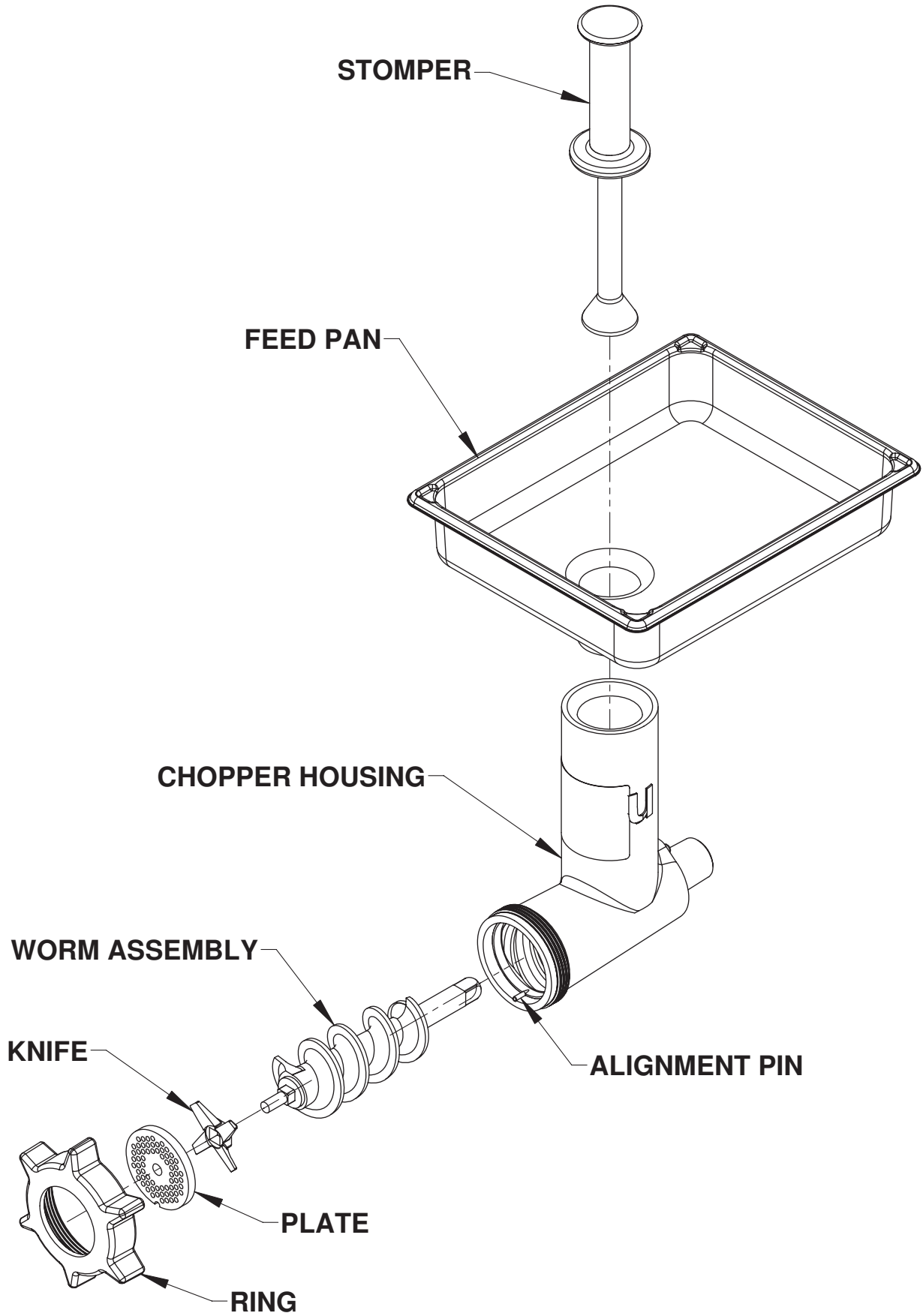

Warranty

The Univex ALMFC Meat and Food Chopper carries a six (6) month, carry-in parts and labor warranty against any defects in materials or workmanship. The six month period begins on the date of purchase by the end user and remains in full effect provided the unit is used properly and in accordance with our instructions for six months. Please call the Univex Warranty Service Department at 800-258-6358 to report warranty claims before arranging repair of the unit. The unit must be delivered to Univex authorized service agent or to the Univex facility for warranty repairs. The end user is responsible for all travel or shipping charges arising from the repair or servicing of this unit under warranty. Any service or repair must take place in the United States. Univex will not cover over-time charges of any kind.

Damages incurred in transit or incurred because of installation error, accident, alteration, or misuse are not covered by this warranty. Transit damages should be reported to the carrier immediately.

Univex will not be liable for any consequential, compensatory, incidental or special damages.

