



MG8912 MEAT & FOOD GRINDER OPERATOR'S MANUAL



Persons under age 18 are not permitted to operate or have accessibility to operate this equipment per U.S. Dept. Of Labor Employment Standards Administration Fact Sheet No. ESA913.

TABLE OF CONTENTS

<u>DESCRIPTION</u>	<u>PAGE</u>
TABLE OF CONTENTS	1
LIST OF ILLUSTRATIONS	1
INSPECTION	2
SAFETY	3
ASSEMBLY INSTRUCTIONS.....	5
OPERATING INSTRUCTIONS	7
WARRANTY	BACK COVER

LIST OF ILLUSTRATIONS

<u>ILLUSTRATION</u>	<u>PAGE</u>
FIGURE 1 OVERALL VIEW	4
FIGURE 2 POWER TAKE-OFF HUB (PTO)	6
FIGURE 3 WORM ASSEMBLY	6
FIGURE 4 GRINDER WITH PAN AND STOMPER	8

MODEL MG8912 MEAT GRINDER

INSTRUCTION MANUAL

Welcome to Univex

Thank you for purchasing this Univex Product.

Your new MG8912 Meat Grinder has been designed with advanced performance and safety features that make it an excellent addition to your food preparation equipment. Like all Univex mixers, slicers, meat grinders and accessories, this meat grinder is engineered to provide years of reliable service.

If you have any questions concerning the operation of this unit, or if we can be of further assistance, please call our Customer Service Department for the location of your nearest service representative.

Univex Customer Service:

USA & Canada 800-258-6358

International 603-893-6191

Or visit us on-line at www.univexcorp.com under service agents.

The UNIVEX Model MG8912 Meat Grinder is a portable electric powered machine designed to process 8 to 12 pounds of meat per minute. It consists of a 1 HP drive assembly with a No. 12 drive hub operating at 250 RPM, a grinder head assembly with interchangeable plates to vary the texture of the processed meat, an 8 quart feed pan to hold the meat that is to be processed, and a stomper to push the meat into the grinder.

INSPECTION

The MG8912 Meat Grinder has been inspected and tested at the factory, however the user should examine the grinder head assembly and compare it with the parts list on page 8. The drive assembly is complete and requires only an external inspection and electrical check prior to use. The electrical data listed on the nameplate of the drive unit should be the same as the user's electrical supply. Any damage should be reported to the carrier immediately and any shortage or deviation of parts should be reported to Univex Corporation.

SAFETY IS OUR TOP PRIORITY

READ AND MAKE SURE THAT YOU UNDERSTAND THE INSTRUCTIONS AND SAFETY WARNINGS IN THIS BOOKLET BEFORE ATTEMPTING TO OPERATE THIS MEAT GRINDER.

NEVER PUT FINGERS OR HANDS IN THE THROAT OF THE GRINDER WHILE THE GRINDER IS OPERATING OR SERIOUS INJURY WILL RESULT.

NEVER ATTEMPT TO CLEAR JAMMED PRODUCT WITHOUT SHUTTING THE POWER OFF AND DISCONNECTING THE ELECTRICAL POWER SUPPLY CORD.

IT IS A VIOLATION OF UNITED STATES DEPARTMENT OF LABOR REGULATIONS TO PERMIT OPERATION OF THIS UNIT BY ANY PERSON UNDER THE AGE OF 18 YEARS.

SWITCH THE POWER “OFF” BEFORE CONNECTING THE UNIT TO THE POWER SOURCE, OR RESETTING THE CIRCUIT BREAKER. MAKE SURE THE SWITCH IS IN THE “OFF” POSITION, OR THE MACHINE WILL START WHEN THE ELECTRICAL POWER IS RESTORED.

A MANUAL RESETTABLE OVERLOAD CIRCUIT BREAKER IS PROVIDED ON THE BACK OF THE MACHINE. IF THE CIRCUIT BREAKER IS TRIPPED, SWITCH THE POWER “OFF”, DISCONNECT THE ELECTRICAL POWER SUPPLY CORD, DETERMINE AND CORRECT THE FAULT AND RESET THE BREAKER.

WHEN THE UNIT IS NOT IN USE, PLACE THE ON/OFF SWITCH IN THE “OFF” POSITION AND REMOVE THE SWITCH KEY BY PINCHING THE KEY BETWEEN THE THUMB AND FOREFINGER AND PULLING IT FROM THE SWITCH. REMOVING THE KEY WILL PREVENT THE SWITCH FROM BEING SET TO THE “ON” POSITION.

ASSURE THAT THE MEAT CHOPPER IS PROPERLY ASSEMBLED AND INSTALLED WITH THE THUMB SCREW TIGHTENED BEFORE CONNECTING THE ELECTRICAL SUPPLY.

THE KNIFE IS **SHARP**. USE EXTREME CARE WHEN HANDLING OR CLEANING IT.

DO NOT PUT YOUR FINGERS INTO THE THROAT OF THE GRINDER WHEN THE ELECTRICAL POWER SUPPLY IS CONNECTED. USE THE STOMPER TO PUSH MEAT INTO THE GRINDER THROAT.

DO NOT PUT FINGERS OR OBJECTS INTO THE HOLES IN THE PLATES.

WIPE DOWN THE EXTERIOR OF THE DRIVE UNIT ONLY, NEVER HOSE DOWN OR IMMERSE THE DRIVE UNIT IN WATER.

DO NOT ATTEMPT TO SERVICE THE DRIVE ASSEMBLY. PLEASE CONTACT UNIVEX CORPORATION FOR THE NUMBER OF THE NEAREST AUTHORIZED SERVICE AGENT IN YOUR AREA FOR ADJUSTMENTS OR REPAIR.

OVERALL VIEW OF MEAT GRINDER

FIGURE 1

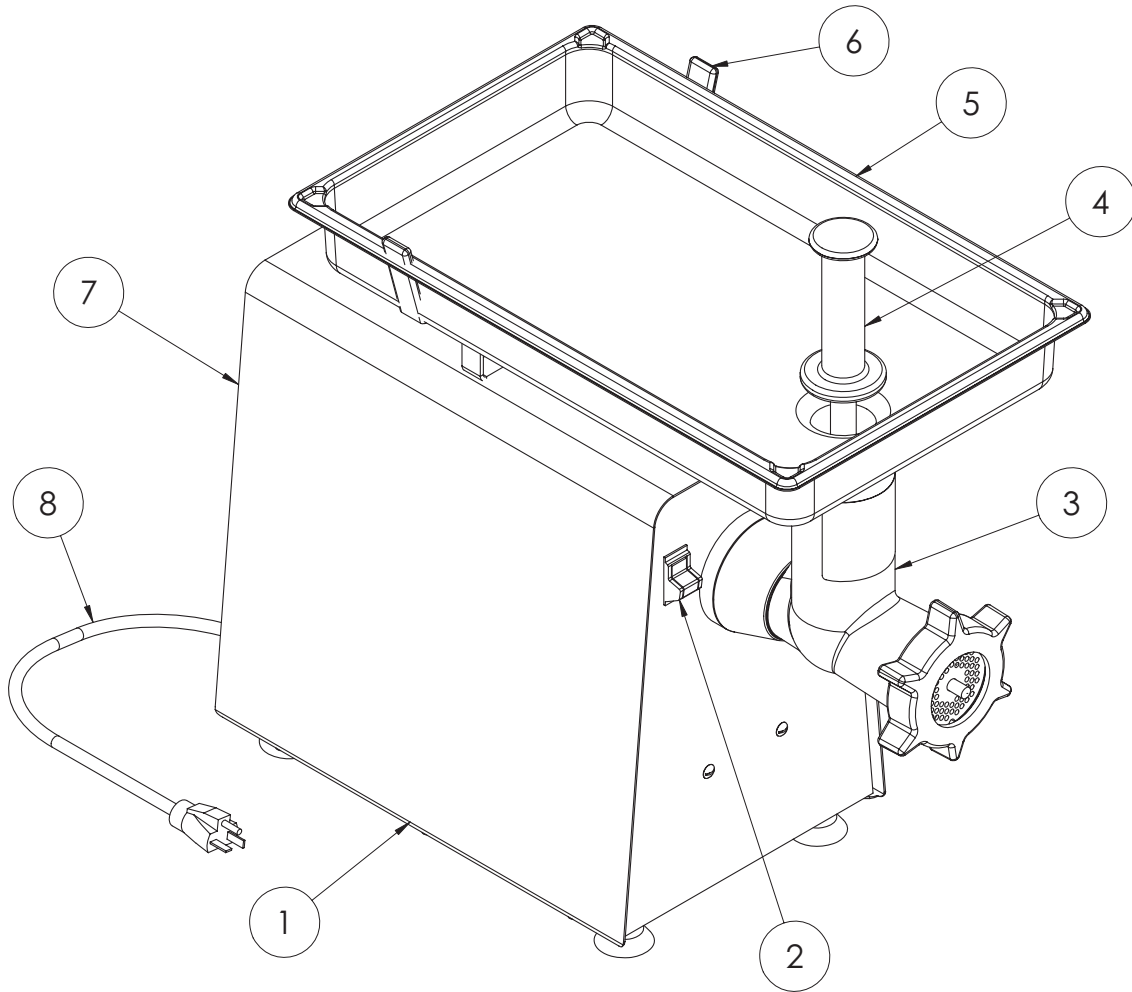

1. POWER UNIT

2. POWER SWITCH

3. GRINDER HEAD

4. STOMPER

5. FEED PAN

6. PAN SUPPORT

7. CIRCUIT BREAKER (ON BACK)

8. POWER CORD

ASSEMBLY INSTRUCTIONS

Attach the pan support (Figure 1 [6]) to the housing cover using two 10-32 pan head screws. The PTO adapter (Figure 2) should remain on the PTO drive shaft when the grinding head is removed. The components of the grinder assembly should be washed with a warm water and mild soap solution and dried prior to use. Inspect the knife (Figure 4 [6]) for sharpness and handle it with care.

Remove the PTO cover cap. Insert the grinder housing (Figure 4 [4]) into the PTO hub of the drive unit. Align the pin in the grinder housing with the hole in the PTO hub and push the grinding head fully into the PTO. Tighten the thumb screw to secure the grinder head to the PTO.

Lightly coat the drive shaft and fiber washer of the worm assembly with Petrol-Gel. Insert the worm assembly into the grinder housing aligning the square shaft end with the PTO adapter and fully engaging it in the PTO adapter.

The knife (Figure 4 [6]) and grinder plate (Figure 4 [7]) should be coated with Petrol-Gel or beef tallow prior to assembly. Place the knife, **sharp edges facing out**, on the square extension of the worm assembly. Place the grinder plate on the pin in the end of the worm and into the grinder housing aligning the notch in the plate with the pin in the grinder housing. Screw the ring (Figure 4 [8]) onto the grinder housing using only minimum force. The ring controls the pressure between the plate and the knife. The knife is easily damaged by running dry or excessive force on the ring.

Insert the spout on the feed pan into the throat of the grinder and rest the pan on the pan support bracket on the drive unit.

POWER TAKE-OFF HUB (PTO)

FIGURE 2

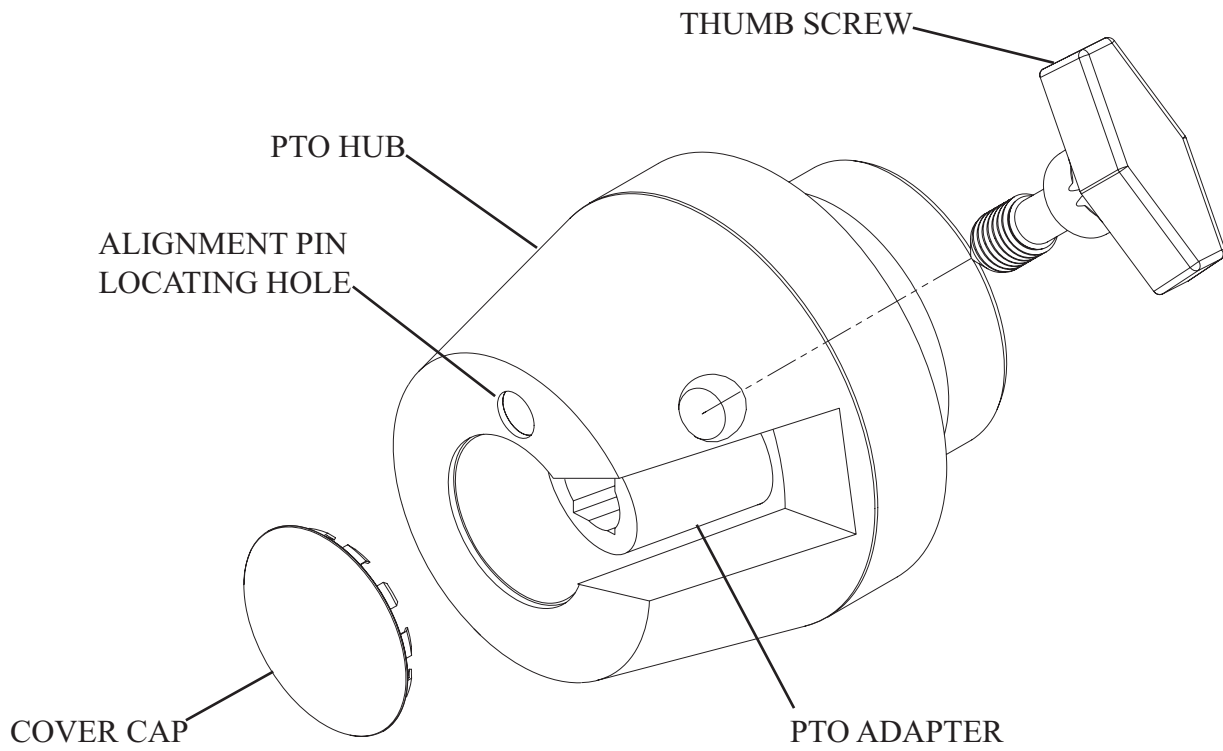

WORM ASSEMBLY

FIGURE 3

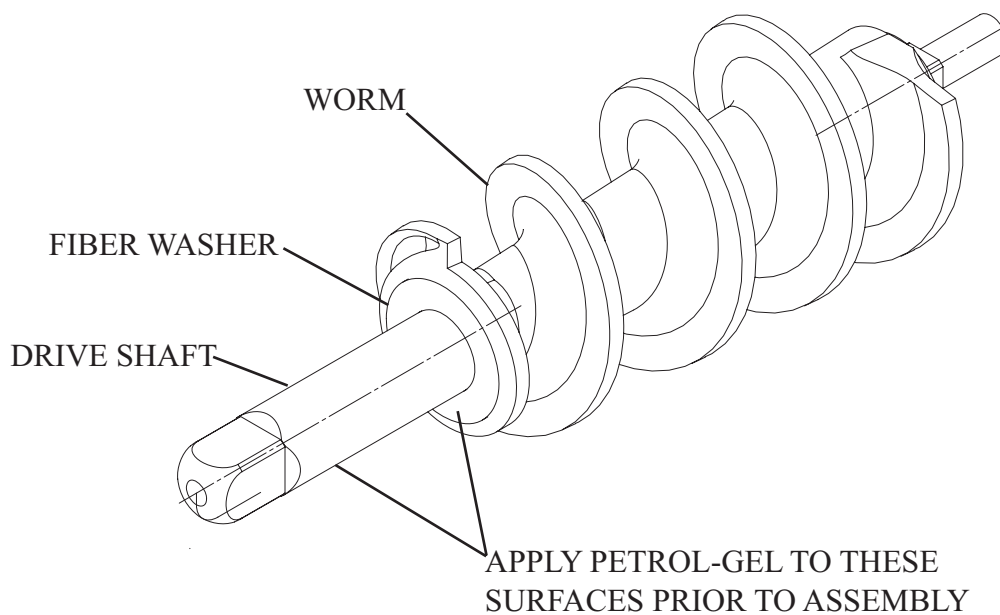

OPERATING INSTRUCTIONS

Choose a location for the MG8912 that is convenient for the operator, allowing free access to the power switch and sufficient clearance for safety and care of operation.

Slice the meat into strips which will easily fit into the throat of the grinder.

Place a suitable container at the discharge of the grinder.

Place the meat in the feed pan and start the grinder.

Hand feed the meat into the grinder. **DO NOT** place fingers inside the throat of the grinder, use the stomper to push the meat into the worm. Do not use the stomper to force feed the meat into the grinder at an increased rate. Best results are obtained when the meat is fed only as fast as the grinder processes it.

Switch the power "OFF" when processing is interrupted.

When the processing has been completed, switch the power "OFF" and disconnect the power supply cord.

Dismount the grinder from the drive unit and disassemble, wash and dry the components of the grinder.

Store the components in a refrigerator for added sanitation.

GRINDER WITH PAN AND STOMPER

FIGURE 4

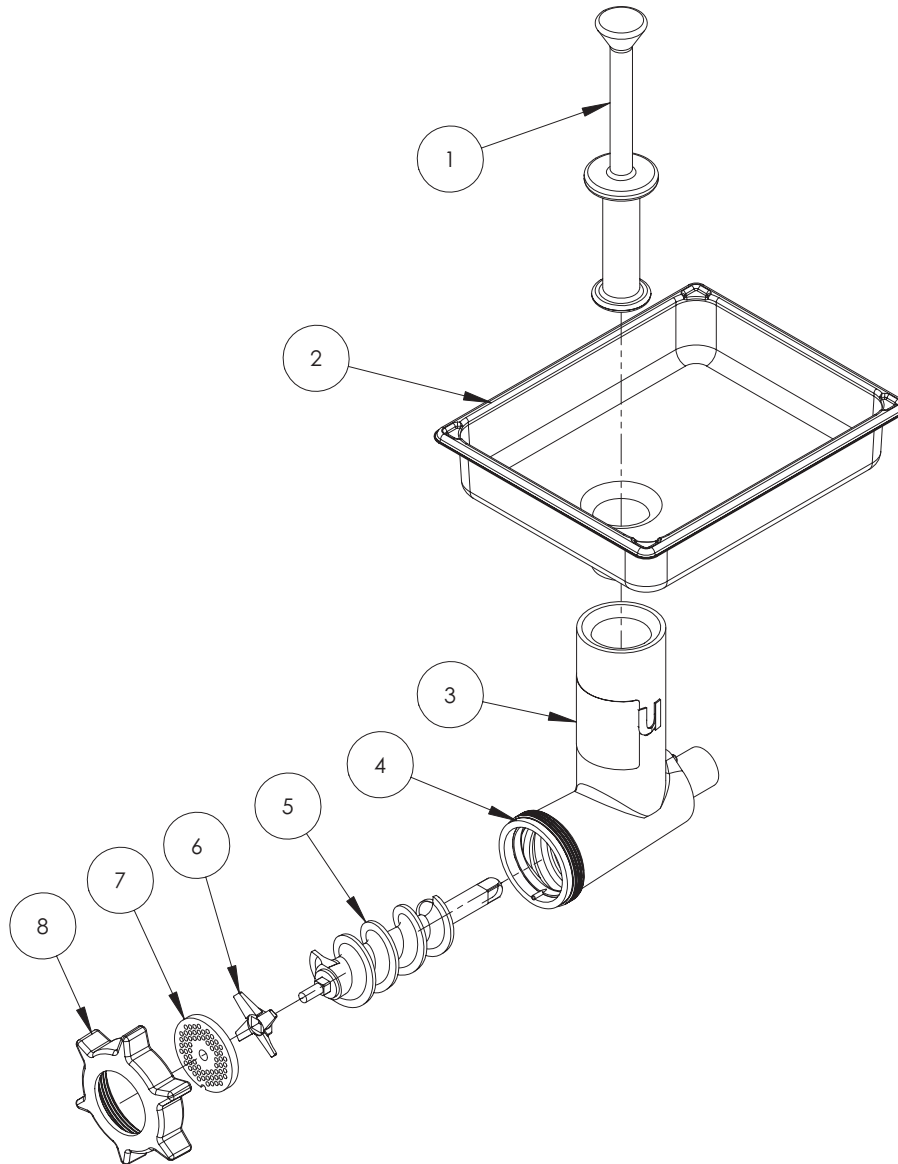

ITEM No.	PART No.	DESCRIPTION	Qty.
1	1000735	Stomper	1
2	8700011	Pan, Stainless Steel	1
3	4400351	Label	1
4	1000651	Housing Assembly	1
5	1000653	Worm Assembly	1
6	1000506	Knife	1
7	1000509	Plate 3/16	1
	1000508	Plate 1/8 (optional)	1
	1000510	Plate 1/4 (optional)	1
	1000511	Plate 3/8 (optional)	1
	1000512	Plate 1/2 (optional)	1
8	1000652	Ring	1
9	4400408	Petrol-Gel (not shown)	1

Warranty

The Univex MG8912 meat grinder carries a one-year, on-site parts and labor warranty against any defects in materials or workmanship. The one-year period begins on the date of purchase by the end user and remains in full effect provided the unit is used properly and in accordance with our instructions. Any work to be performed under this warranty must be performed between the hours of 8:00 am and 5:00 pm local time, Monday through Friday. Univex will not cover over-time charges of any kind. Please call the Univex Warranty Service Department at 800-258-6358 to report warranty claims before arranging repair or attempting to return the unit to Univex Corporation.

Damages incurred in transit or incurred because of installation error, accident, alteration, or misuse are not covered by this warranty. Transit damages should be reported to the carrier immediately.

Univex will not be liable for any consequential, compensatory, incidental or special damages.

