



4", 5" & 6" PATTY PRESS OPERATOR'S MANUAL



Persons under age 18 are not permitted to operate or have accessibility to operate this equipment per U.S. Dept. Of Labor Employment Standards Administration Fact Sheet No. ESA913

INSTRUCTION MANUAL

INTRODUCTION

The Univex model 1404, 1405 and 1406 Patty Presses are designed to press hamburger meat into patties. The 1404 Patty Press produces a 4 inch diameter patty, the 1405 Patty Press produces a 5 inch diameter patty and the 1406 Patty Press produces a 6 inch diameter patty.

The Univex Patty Press can be used to form patties of food products other than hamburger such as: crab cakes, fish cakes and vegetable burgers.

The thickness of the patties produced is determined by the amount of hamburger or other food products placed in the press.

This manual contains instructions for the inspection, safe operation, care and maintenance of the Patty Press.

INSPECTION

The 1404, 1405 and 1406 Patty Press is inspected and tested at the factory. The person opening the shipping carton should re-inspect the Patty Press immediately upon receipt for loose, damaged or missing parts. Any damages should be reported to the carrier immediately and any shortages of parts should be reported to your dealer or directly to Univex Corporation Customer Service Department.

OVERALL VIEW OF PATTY PRESS

FIGURE 1

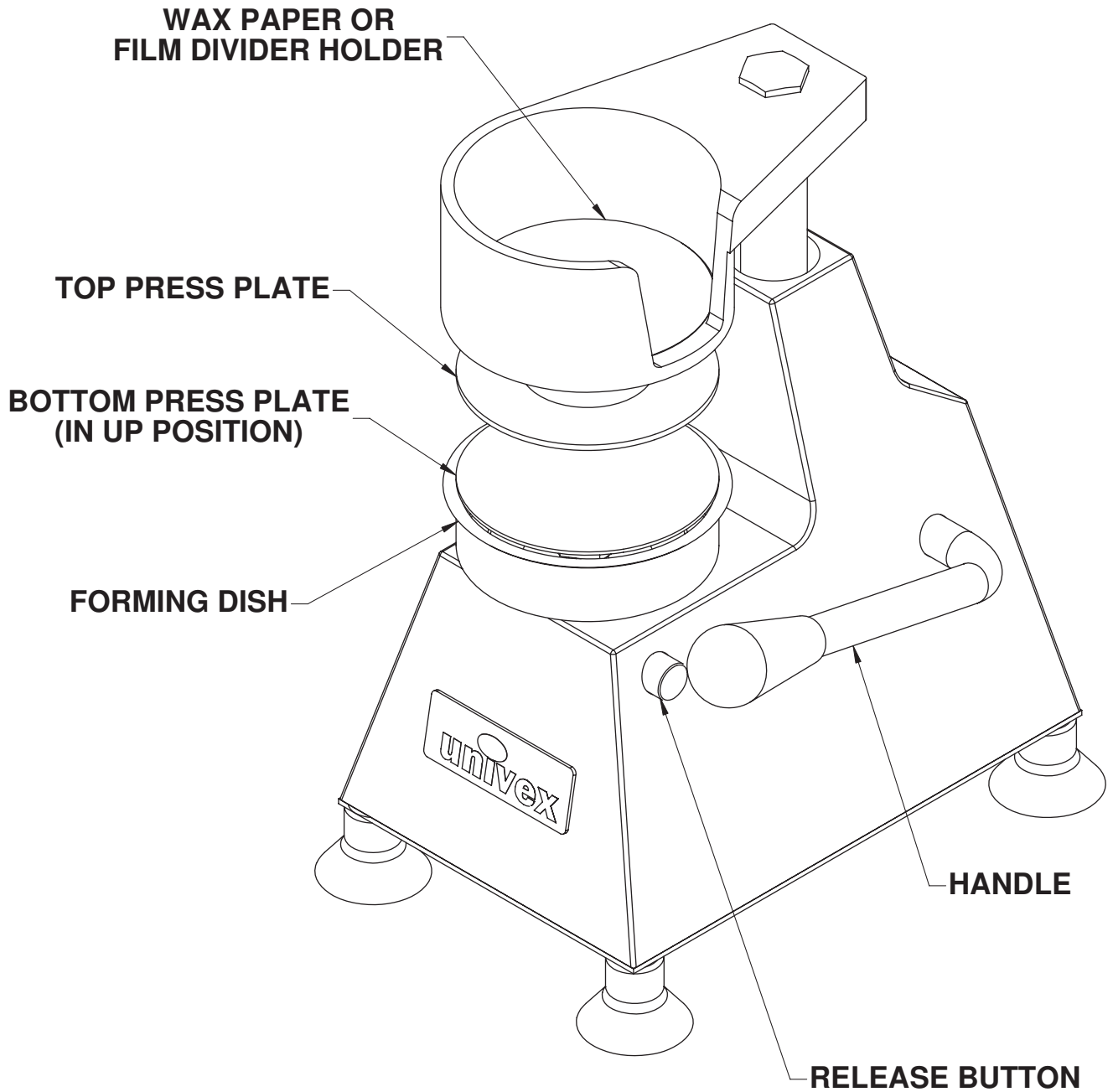

OPERATORS INSTRUCTIONS

- 1 Push the handle all the way back (see figure 1).
- 2 Place a ball of hamburger meat on the bottom press plate.
- 3 Press the release button to lower the press plate into the forming dish.
- 4 Pull the handle all the way forward and apply light pressure to form the patty.
- 5 Push the handle all the way back. The press plate rises automatically for easy removal of the formed patty.
- 6 Repeat steps 1-5 for each patty.

If you plan to stack finished patties for future use, place a film or paper divider (provided with the Patty Press) on the press plate before loading it with hamburger meat.

A working supply of dividers can be kept in the film divider holder above the top press plate (see figure 1).

1000556 4" ROUND, 5000 pcs

1000557 5" ROUND, 5000 pcs

1000601 6" ROUND, 5000pcs

CLEANING

To avoid damaging the Patty Press's high polished finish, never put any of the components through a dishwashing machine. Wash the Patty Press with a mild soap and water solution. Use a brush in small areas. Dry components with a soft dry cloth.

Warranty

The Univex 1404/1405/1406 Patty Press is warranted by Univex Corporation against any defects in materials or workmanship for a period of 6 months from the date of purchase by the end user. Please call the Univex Warranty Service Department at 800-258-6358 to report warranty claims before arranging for repair of the unit. The unit must be delivered to a Univex authorized service agent or to the Univex facility for warranty repairs. The end user is responsible for all shipping or travel charges arising from the repair or servicing of this unit under warranty. Univex will not cover overtime charges of any kind. Any service or repair must take place in the United States.

Damages incurred in transit or incurred because of installation error, accident, alteration or misuse are not covered. Transit damages should be reported to the carrier immediately.

Univex will not be liable for any consequential, compensatory incidental or special damages.

