

Project _____

Item Number _____

Quantity _____

SBLA



Models:

- SBLA



Features:

- Adjustable height
- Simple reliable service
- Easy controls
- Built in safety guard

Bowl Lifters

System Information:

- System Motor:** 220V/60Hz/3ph
- Machine Weight:** 2866 lbs
- Capacity:** 3306 lbs

Note:

Please allow 6 inches beyond posted dimensions for complete clearance.

Univex Corporation

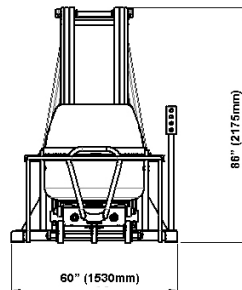
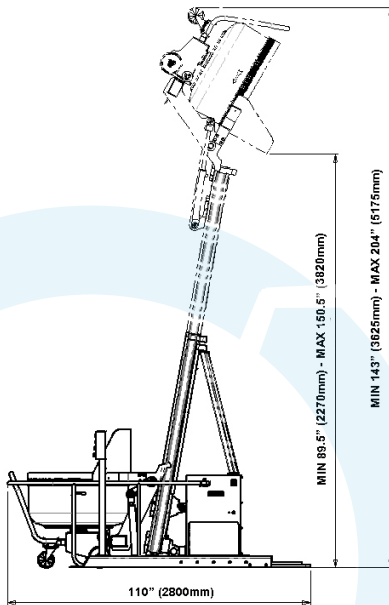

Warranty:

- One year, on-site parts and labor