

Project _____

Item Number _____

Quantity _____

SL160LH/SL160LB



SL160LH / SL160LB SILVERLINE Spiral Mixers with Attached Lifter

Models:

- SL160LH: 350lbs (160Kg) Spiral Mixer
- SL160LB: 350lbs (160Kg) Spiral Mixer

SILVERLINE Spiral Mixer
with Attached Lifter

Features:

- Stainless steel bowl, spiral dough hook, and shaft
- Separate bowl and agitator motors
- Has two speeds and reverse function
- Control board has separate timers for 1st and 2nd speed
- Mixer is equipped with built in lifter for lifting and discharge of mixed products
- Lifter can tilt machine to the right or left (must specify when ordering)
- Difference between H and B models is the height of the lifter (one for bench top and one for hoppers)
- Safety switches protect operator from injury if bowl lid is open
- Powerful belt drive provides low vibration, low noise, and economical maintenance for years of reliable service



Univex Corporation

Dough hook:

1st speed: 95rpm
2nd speed: 190rpm
Bowl Speed: 15rpm

Warranty:

- One year, on-site parts and labor



WE RAISE THE BAR. WE SET THE STANDARD.

SILVERLINE Spiral Mixer with Attached Lifter

SL160LH/SL160LB

SL160LH

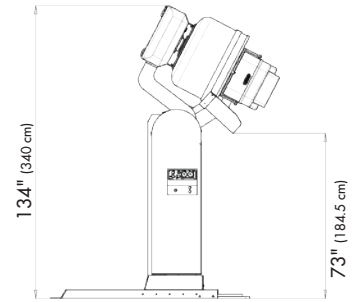
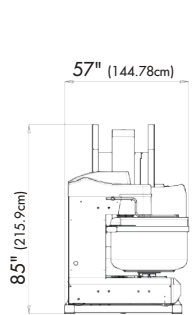
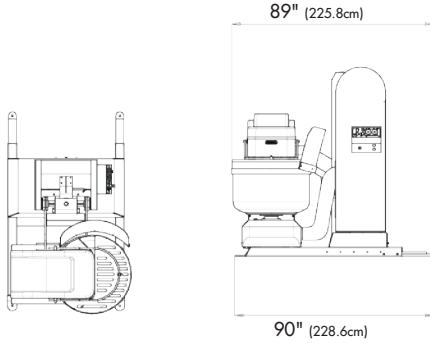

SL160LB

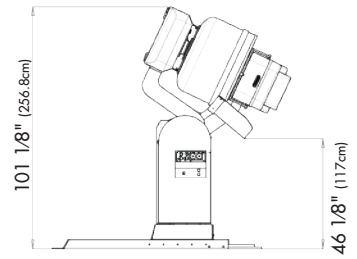
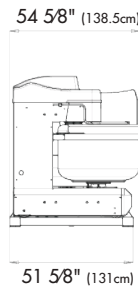
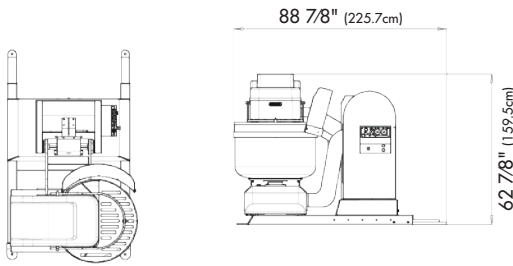

Electrical Information (60Hz)

Model	Voltage	Phase	Spiral hp(kW)	Bowl hp(kW)	Lifter hp(kW)	Total hp(kW)	Spiral Amps	Bowl Amps	Lifter Amps	Total Amps
SL160LH	220	3	15 (11)	1 (.75)	3 (2.2)	19 (13.95)	52.8	4.48	13	57.28
SL160LH Optional Voltage	400	3	15 (11)	1 (.75)	3 (2.2)	19 (13.95)	26.4	2.24	6.5	29
SL160LB	220	3	15 (11)	1 (.75)	3 (2.2)	19 (13.95)	52.8	4.48	13	57.28
SL160LB Optional Voltage	400	3	15 (11)	1 (.75)	3 (2.2)	19 (13.95)	26.4	2.24	6.5	29

Transmission: Heavy duty low noise, low vibration belt drive.

Bowl Guard: Swings open for full access to bowl. Guard must be closed for mixer operation.

Controls: Control panel with manual timers. Separate timers for high and low speed. Security key for manual use. Bowl reverse direction switch.

Plug Info:

Hard Wire With Shutoff

Shipping Information

Model	Net Weight	Shipping Weight	Overall Dimensions
SL160LH	4,188 lbs. (1,900Kg)	4,538 lbs. (2,058Kg)	91" (231.1cm) H x 96" (243.8cm) W x 60" (152.4cm) D
SL160LB	3,527 lbs. (1,600Kg)	3,877 lbs. (1,759Kg)	71" (180.3cm) H x 96" (243.8cm) W x 60" (152.4cm) D



Univex Corporation
www.Univexcorp.com

3 Old Rockingham Rd
Salem, NH 03079
United States of America

TEL: (800)258-6358
INTL TEL: (603)893-6191
FAX: (800)356-5614
INTL FAX: (603)893-1249