

Project _____

Item Number _____

Quantity _____

SL80RB / SL120RB



SL80RB / SL120RB SILVERLINE Spiral Mixers with Removable Bowl

Models:

- SL80RB: 137 quart (130 Liter) Spiral Mixer
- SL120RB: 180 quart (170 Liter) Spiral Mixer



Spiral Mixer
with Removable Bowl

Features:

- Stainless steel bowl, spiral dough hook, and shaft
- Separate bowl and agitator motors
- Has two speeds and reverse function
- Control board has separate timers for 1st and 2nd speed
- Safety switches protect operator from injury if bowl lid is open
- Powerful belt drive provides low vibration, low noise, and economical maintenance for years of reliable service

Standard Accessories:

- Stainless steel bowl
- Dolly with bowl for 80 or 120 depending on machine
- Electromagnetic hook for bowl

Optional Accessories:

- Extra dolly with bowl

Univex Corporation

Dough Capacity:

SL80RB: 176lb (80kg)
SL120RB: 265lb (120kg)

Dough hook:

1st speed: 95 rpm
2nd speed: 190 rpm

Bowl:

20 rpm

Warranty:

- One year, on-site parts and labor



WE RAISE THE BAR. WE SET THE STANDARD.

SILVERLINE Spiral Mixer with Removable Bowl SL80RB / SL120RB

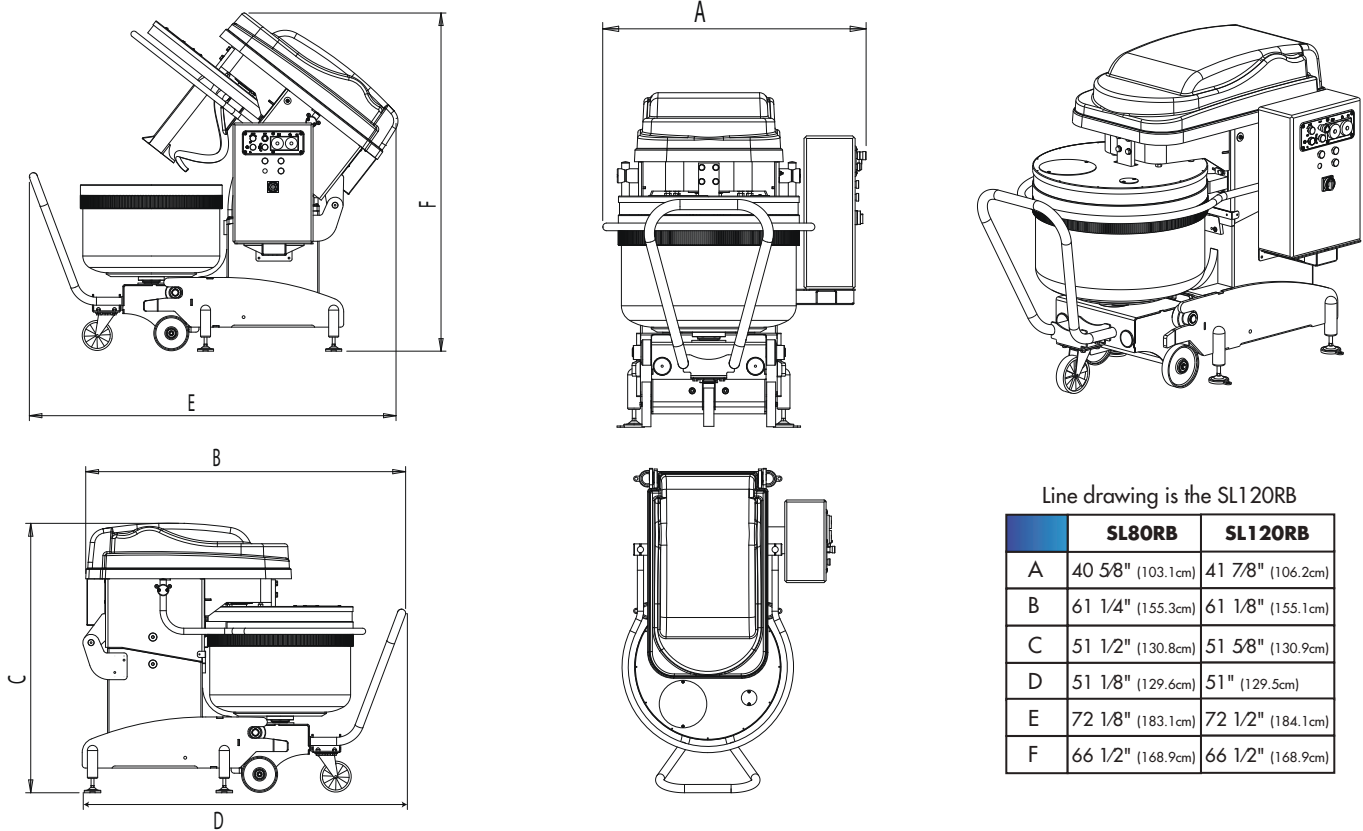

Line drawing is the SL120RB

	SL80RB	SL120RB
A	40 5/8" (103.1cm)	41 7/8" (106.2cm)
B	61 1/4" (155.3cm)	61 1/8" (155.1cm)
C	51 1/2" (130.8cm)	51 5/8" (130.9cm)
D	51 1/8" (129.6cm)	51" (129.5cm)
E	72 1/8" (183.1cm)	72 1/2" (184.1cm)
F	66 1/2" (168.9cm)	66 1/2" (168.9cm)

Transmission: Heavy duty low noise and low vibration belt drive.

Bowl Guard: Swings open for full access to bowl. Guard must be closed for mixer operation.

Plug Info: Hard Wire With Shutoff

Controls: Control panel with digital timers. Separate timers for high and low speed.

Security key for manual use. Bowl reverse direction switch.

True 3 phase power is required, Delta or other semi 3 phase power set up 's will not work

Electrical Information (60Hz)

Model	Standard Voltage	Phase	Spiral hp(kW)	Bowl hp(kW)	Head hp(kW)	Total hp(kW)	Spiral Amps	Bowl Amps	Head Amps	Total Amps
SL80RB	220	3	11 (8)	1 (.75)	1 (.75)	13 (9.50)	38.5	4.48	4.48	47.46
SL80RB Optional	380	3	11 (8)	1 (.75)	1 (.75)	13 (9.50)	19.25	2.24	2.24	21.49
SL120RB	220	3	11 (8)	1 (.75)	1 (.75)	13 (9.50)	38.5	4.48	4.48	47.46
SL120RB Optional	380	3	11 (8)	1 (.75)	1 (.75)	13 (9.50)	19.25	2.24	2.24	21.49

Shipping Information

Model	Net Weight	Shipping Weight	Overall Dimensions
SL80RB	1,410 lbs. (639.6Kg)	1,521 lbs. (689.9Kg)	79" (200.7cm) H x 41" (104.1cm) W x 73" (185.4cm) D
SL120RB	1,433 lbs. (650Kg)	1,543 lbs. (699.9Kg)	79" (200.7cm) H x 41" (104.1cm) W x 73" (185.4cm) D

*The weight and dimensions of the pallet are included in the weight and dimensions above.



Univex Corporation
www.Univexcorp.com

3 Old Rockingham Rd
Salem, NH 03079
United States of America

INTL TEL: (800)258-6358

TEL: (603)893-6191

INTL FAX: (800)356-5614

FAX: (603)893-1249