

Project \_\_\_\_\_

Item Number \_\_\_\_\_

Quantity \_\_\_\_\_

SRM30+ Mixer



## 30 Quart (qt.) Floor Model Mixer MADE IN THE USA

### Model:

➤ SRM30+: 30 qt. FLOOR MODEL MIXER



Floor Model Mixer

### Features:

- 1 hp capacitor start motor
- Variable Speed Drive: 4 fixed speeds or any speed in-between
- Change speeds without having to stop the mixer
- Two-piece, stainless steel, dishwasher safe safety guard
- #12 Power Take Off (PTO) hub
- Heavy-duty stainless steel bowl
- Interlock switches protect operator from injury if safety guard is open or bowl is lowered
- Hardened alloy gears in transmission
- Low voltage protection prevents accidental start up after power failure
- Durable NSF approved hybrid epoxy/polyester powder coat finish

### Standard Accessories:

- 15 minute timer
- 30 qt. stainless steel bowl
- Dough hook
- Batter beater
- Wire whip
- Ingredient chute
- Bowl scraper

### Optional Accessories:

- Bowl truck
- Sweet dough beater
- Splash ring
- 30 qt. pastry knife
- Four wing beater
- Cover

### Optional Attachments:

- VS9 vegetable slicer with adjustable knife
- VS9H vegetable shredder with plate holder and 3/16" plate (additional plate size variations, grater plates, and julienne plate available)
- ALMFC12 meat and food grinder

### Warranty:

- Two year, on-site parts and labor

Univex Corporation



WE RAISE THE BAR. WE SET THE STANDARD.

# 30 Quart Floor Model Mixer

# SRM30+

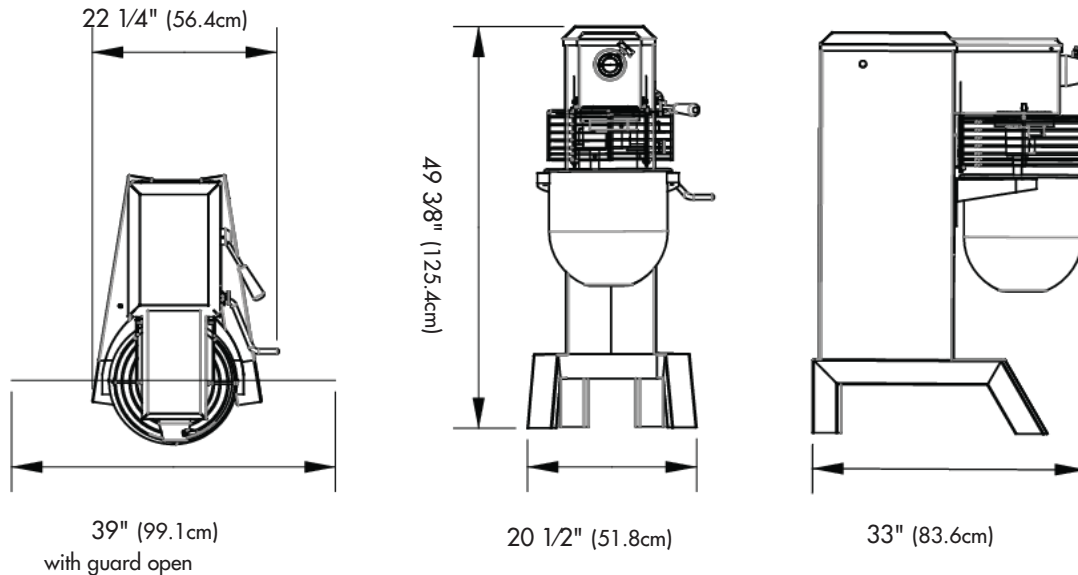

### Shipping Information

Net Weight	Shipping Weight	Overall Dimensions
330 lbs. (149.7Kg)	400 lbs. (176.9Kg)	56" (142.2cm) H x 36" (91.4cm) W x 33" (83.8cm) D
The weight and dimensions of the pallet are included in the weight and dimensions above.		

### Electrical Information (60Hz)

Attached 6 foot cord

	Voltage	Phase	AMPS	NEMA
Standard	115	1	14.4	5-15P
Optional	208-240	1	6.8-7.2	6-15P
	208-240	3	4.4-4.2	11-15P
	460	3	2.1	L16-20

### Mixer Speeds

Speed	1	2	3	4
Beater Shaft (RPM)	110	245	423	488
PTO (RPM)	64	143	248	295

Bowl Capacity: 30 qts. (28.3 liters)

Motor: 1 hp capacitor start

Controls: Momentary contact stop & start buttons and contactor

Bowl Lift: Ergonomic hand operated crank, self locking in top and bottom position

Transmission: Featuring hardened alloy gearing and torque sensing variable speed pulleys

Power Take Off (PTO): #12 Hub



**Univex Corporation**  
www.Univexcorp.com

3 Old Rockingham Rd  
Salem, NH 03079  
United States of America

TEL: (800)258-6358  
INTL TEL: (603)893-6191  
FAX: (800)356-5614  
INTL FAX: (603)893-1249