

Project _____

Item Number _____

Quantity _____

SRM60+ Mixer



60 Quart (qt.) Floor Model Mixer

MADE IN THE USA

Model:

➤ SRM60+: 60 qt. FLOOR MODEL MIXER



Floor Model Mixer

Features:

- 3 hp capacitor start motor
- Variable Speed Drive: 4 fixed speeds or any speed in-between
- Change speeds without having to stop the mixer
- Two-piece, stainless steel, dishwasher safe safety guard
- #12 Power Take Off (PTO) hub
- Heavy-duty stainless steel bowl
- Interlock switches protect operator from injury if safety guard is open or bowl is lowered
- Hardened alloy gears in transmission
- Low voltage protection prevents accidental start up after power failure
- Durable NSF approved hybrid epoxy/polyester powder coat finish

Standard Accessories:

- 15 minute timer
- Wire whip
- Dough hook
- Batter beater
- 60 qt. stainless steel bowl
- Ingredient chute
- Bowl scraper
- Power bowl lift

Optional Accessories:

- Splash ring
- Cover
- Bowl truck
- Sweet dough beater
- 60 qt. pastry knife
- Four wing beater
- Heavy duty SS wire whip

Optional Attachments:

- VS9 vegetable slicer with adjustable knife
- VS9H vegetable shredder with plate holder and 3/16" plate (additional plate size variations, grater plates, and julienne plate available)
- ALMFC12 meat and food grinder

Warranty:

- Two year, on-site parts and labor

Univex Corporation



WE RAISE THE BAR. WE SET THE STANDARD.

60 Quart Floor Model Mixer

SRM60+

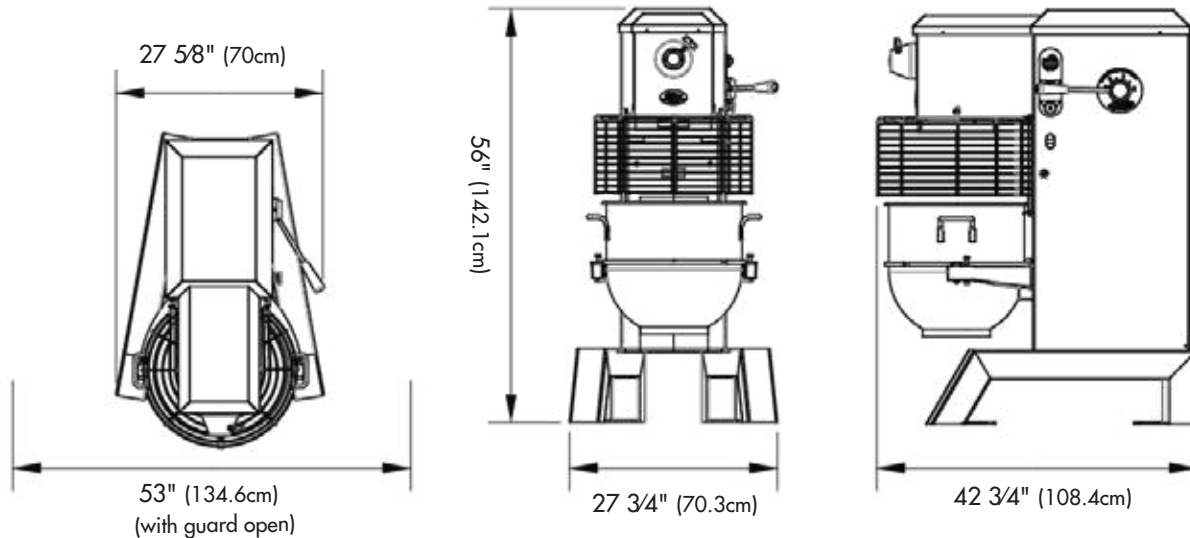

Shipping Information

Net Weight	Shipping Weight	Overall Dimensions
750 lbs (340.2Kg)	1000 lbs (453.6Kg)	66" (167.6cm) H x 41" (104.1 cm) W x 51" (129.5cm) D*
*The and dimensions of the pallet are included in the weight and dimensions above.		

Electrical Information (60Hz)

Attached 6 foot cord

	Voltage	Phase	AMPS	NEMA
Standard	208-240	1	16.0-16.8	6-20P
Optional	208-240	3	8.0-8.5	L15-20
	460	3	4	L16-20

Mixer Speeds

Speed	1	2	3	4
Beater Shaft (RPM)	119	166	275	498
PTO (RPM)	93	132	214	390

Bowl Capacity: 60 qts. (56.7 Liters)

Motor: 3 hp capacitor start

Controls: Momentary contact stop & start buttons and contactor

Bowl Lift: Power bowl lift standard OR Ergonomic hand operated crank, self locking in top and bottom position

Lubrication: Oil bath

Transmission: Oil bath featuring hardened alloy gearing and torque sensing variable speed pulleys

Power Take Off (PTO): #12 Hub



Univex Corporation
www.Univexcorp.com

3 Old Rockingham Rd
Salem, NH 03079
United States of America

TEL: (800)258-6358
INTL TEL: (603)893-6191
FAX: (800)356-5614
INTL FAX: (603)893-1249