



WE RAISE THE BAR. WE SET THE STANDARD.

Project \_\_\_\_\_

Item Number \_\_\_\_\_

Quantity \_\_\_\_\_

SRM60+PM



## 60 Quart (qt.) Floor Model Pizza Mixer with Dough Hook Only

**MADE IN THE USA**

### Model:

- SRM60+PM: 60 qt. FLOOR MODEL PIZZA MIXER WITH DOUGH HOOK ONLY



### Standard Accessories:

- 15 minute timer
- 60 qt. stainless steel bowl
- Dough hook
- Ingredient chute
- Power bowl lift

### Optional Accessories:

- Splash ring
- Cover
- Sweet dough beater
- Wire whip
- 60 qt. pastry knife
- Four wing beater
- Bowl truck
- Batter beater

### Optional Attachments:

- VS9 vegetable slicer with adjustable knife
- VS9H vegetable shredder with plate holder and 3/16" plate (additional plate size variations, grater plates, and julienne plate available)
- ALMFC12 meat and food grinder

### Warranty:

- Two year, on-site parts and labor

Floor Model Mixer

Univex Corporation

### Features:

- 3 hp capacitor start motor
- Variable Speed Drive: 2 fixed speeds or any speed in-between
- Change speeds without having to stop the mixer
- Two-piece, stainless steel, dishwasher safe safety guard
- #12 Power Take-Off (PTO) hub
- Heavy-duty stainless steel bowl
- Interlock switches protect operator from injury if safety guard is open or bowl is lowered
- Hardened alloy gears in transmission
- Low voltage protection prevents accidental start up after power failure
- Durable NSF approved hybrid epoxy/polyester powder coat finish



Univex Corporation  
www.Univexcorp.com

3 Old Rockingham Rd  
Salem, NH 03079  
United States of America

TEL: (800)258-6358  
INTL TEL: (603)893-6191  
FAX: (800)356-5614  
INTL FAX: (603)893-1249



WE RAISE THE BAR. WE SET THE STANDARD.

# 60 Quart Floor Model Pizza Mixer

# SRM60+PM

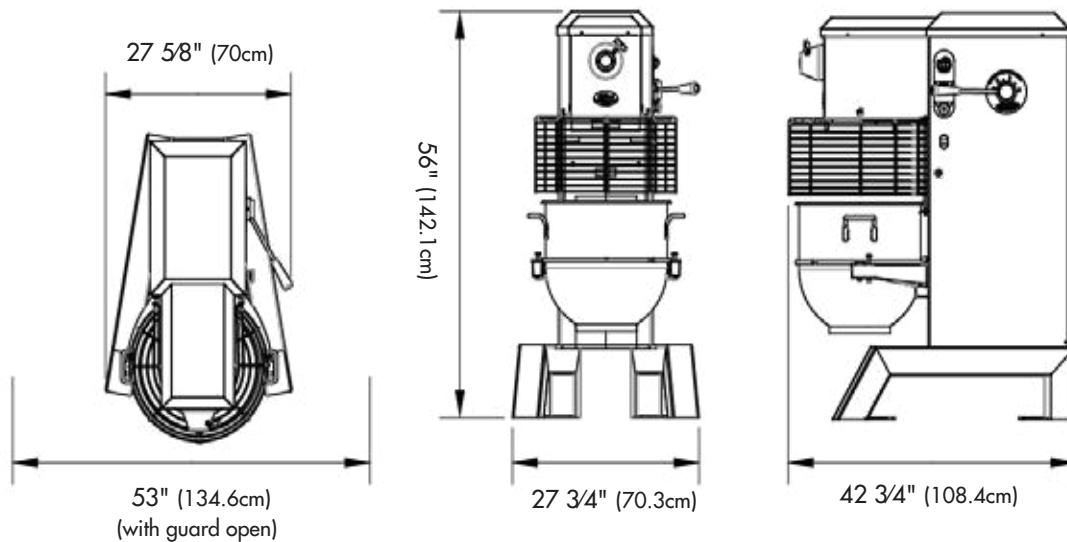

| Shipping Information   |                    |  |
|--|--------------------|--|
| Net Weight   | Shipping Weight    | Overall Dimensions                                   |
| 750 lbs (340.2Kg)  | 1000 lbs (453.6Kg) | 66" (167.6cm) H x 41" (104.1 cm) W x 51" (129.5cm) D |
| The weight and dimensions of the pallet are included in the weight and dimensions above. |                    |  |

| Electrical Information (60Hz) |         |       |           |        |
|-------------------------------|---------|-------|-----------|--------|
| Attached 6 foot cord          |         |       |           |        |
|                               | Voltage | Phase | AMPS      | NEMA   |
| Standard                      | 208-240 | 1     | 16.0-16.8 | 6-20P  |
| Optional                      | 208-240 | 3     | 8.0-8.5   | L15-20 |
|                               | 460     | 3     | 4         | L16-20 |

| Mixer Speeds       |    |     |
|--------------------|----|-----|
| Speed              | 1  | 2   |
| Beater Shaft (RPM) | 90 | 166 |
| PTO (RPM)          | 90 | 163 |

Bowl Capacity: 60 qts. (56.7 liters)

Motor: 3 hp capacitor start

Controls: Momentary contact stop & start buttons and contactor magnetic starter with overload protection

Bowl Lift: Power bowl lift standard OR ergonomic hand operated crank, self locking in top & bottom position

Lubrication: Oil bath

Transmission: Oil bath featuring hardened alloy gearing and torque sensing variable speed pulleys



Univex Corporation  
www.Univexcorp.com

3 Old Rockingham Rd  
Salem, NH 03079  
United States of America

TEL: (800)258-6358  
INTL TEL: (603)893-6191  
FAX: (800)356-5614  
INTL FAX: (603)893-1249