

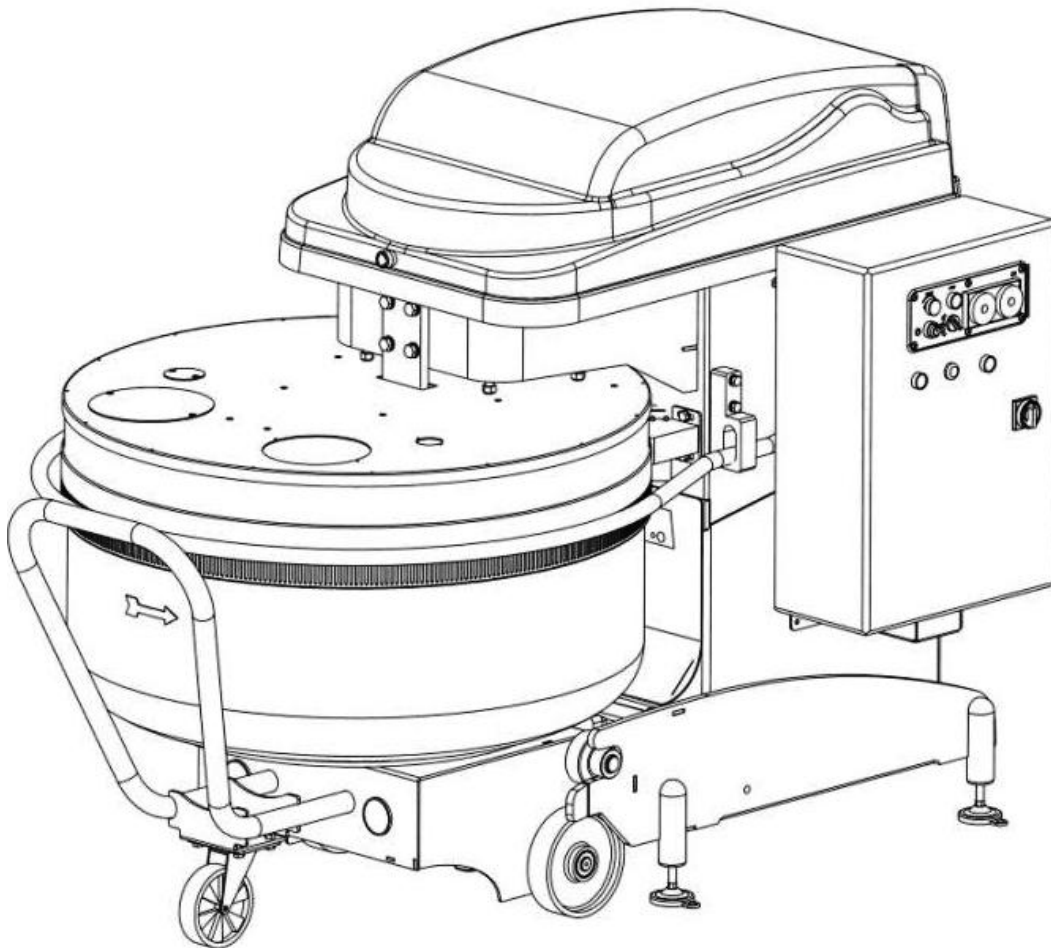

OPERATION MANUAL
SILVER VE 160-200-250-300 MIXER MACHINE WITH
REMOVABLE BOWL



Persons under age 18 are not permitted to operate or have accessibility to operate this equipment per U.S. Dept. Of Labor Employment Standards Administration Fact Sheet No. ESA913.



1. Safe work methods and procedures	4
1.1. Risks for the operator	4
2. Machine description	6
3. Machine identification	7
3.1. Main components	7
4. Technical data and features	8
4.1.1. Technical data	8
4.1.2. Machine dimensions	8
4.1.3. Trolley dimensions	9
4.2. Control panel	9
5. Transport and installation	10
5.1. Transport and handling	10
5.1.1. Machine on pallet	10
5.1.2. Machine without pallet	10
5.2. Description of the adjustment and commissioning operations	11
5.2.1. Installation	11
5.2.2. Electric line connection	11
6. User instructions	12
6.1. Operating instructions	12
6.1.1. To start the machine	12
6.2. Working with the machine	12
7. Maintenance and clearing	13
7.1. Routine maintenance	13
7.2. Machine lock-up and necessary solutions	13
7.3. Machine cleaning	14

INSTRUCTION MANUAL: This manual gives the directions necessary for proper and safe use of this machine and must be read before any of these operations. This manual must be read by the machine operators; it is important for them to know how to carry out their functions properly. This manual is an integral part of the machine and must be kept in a suitable place so as to safeguard its integrity and make it possible to consult it during all machine life.

Compliance with this manual ensures proper operator's use and safety.



Welcome to Univex

Thank you for purchasing this Univex Product.

Your new VE 160-200-250-300 spiral mixer has been designed with advanced performance and safety features that make it an excellent addition to your food preparation equipment. Like all Univex mixers, slicers, meat grinders and accessories, this mixer machine is engineered to provide years of reliable service.

If you have any questions concerning the operation of this unit, or if we can be of further assistance, please call our Customer Service Department for the location of your nearest service representative.

Univex Customer Service:

USA & Canada 800-258-6358

International 603-893-6191

Or visit us on-line at www.univexcorp.com under service agents.

Safety is our top priority

READ AND MAKE SURE THAT YOU UNDERSTAND THE INSTRUCTIONS AND SAFETY WARNINGS IN THIS BOOKLET BEFORE ATTEMPTING TO OPERATE THIS MIXER OR ATTACHMENTS.

NEVER PUT FINGERS OR HANDS UNDERNEATH CARPETS WHILE THE MIXER IS OPERATING OR SERIOUS INJURY COULD RESULT.

NEVER ATTEMPT TO CLEAR THE MACHINE WITHOUT SHUTTING THE POWER OFF

AND DISCONNECTING THE ELECTRICAL POWER SUPPLY.

1. Safe work methods and procedures



READ THESE INSTRUCTIONS CAREFULLY BEFORE USING THE MACHINE

In order to prevent hazardous conditions and/or possible injuries caused by: electric current, mechanical parts, fire, or of hygienic nature, the following safety warnings must be observed:

- Keep your work station tidy. Clutter can cause accidents.
- Assess the environmental conditions. Do not use or leave the machine in a wet, damp or poorly lit environment, or in the vicinity of flammable liquids or gases.
- Keep children and unauthorised personnel away. Do not allow these people to approach the machines or work station.
- Use the machine within its operating range and for the purpose for which it was designed. It works best and at its safest when it is not overloaded.
- Wear appropriate clothing. Do not wear dangling clothes or accessories that may get entangled in moving parts. Use the shoes with reinforced tip and non-slip sole. For health and safety reasons, long hair should be gathered in the appropriate net and gloves should be worn.
- Protect the power supply cable. Do not pull the cable to disconnect the plug. Do not expose the cable to high temperatures, in contact with sharp edges, water or solvents.
- Avoid unsafe positions. Find the most suitable position that ensures absolute stability.
- Always exercise extreme caution.
- Always take the plug out of the socket after use and before cleaning and maintenance and before moving the machine, and leave it in a clearly visible place.
- Never use extension cables outdoors.
- Make sure that the machine is not damaged. Carefully check the effectiveness of the safety devices before using the machine. Make sure that: the mobile parts are locked in place, there are no damaged components, all the parts have been assembled correctly and the machine can be run normally in optimal conditions. (See chapter 14)
- Entrust repairs to qualified personnel. Repairs must only be performed by qualified personnel using original spare parts.

FAILURE TO OBSERVE THESE REQUIREMENTS MAY BE CAUSE OF HAZARD FOR THE USER.

1.1. Risks for the operator



Gripping and dragging hazard: it is present between bowl and structure, between bowl and contrast wheels.



Electrocution hazard: the machine must not be used without adequate earthing, and it must be connected to a system built according to building regulations in force in the country of installation.

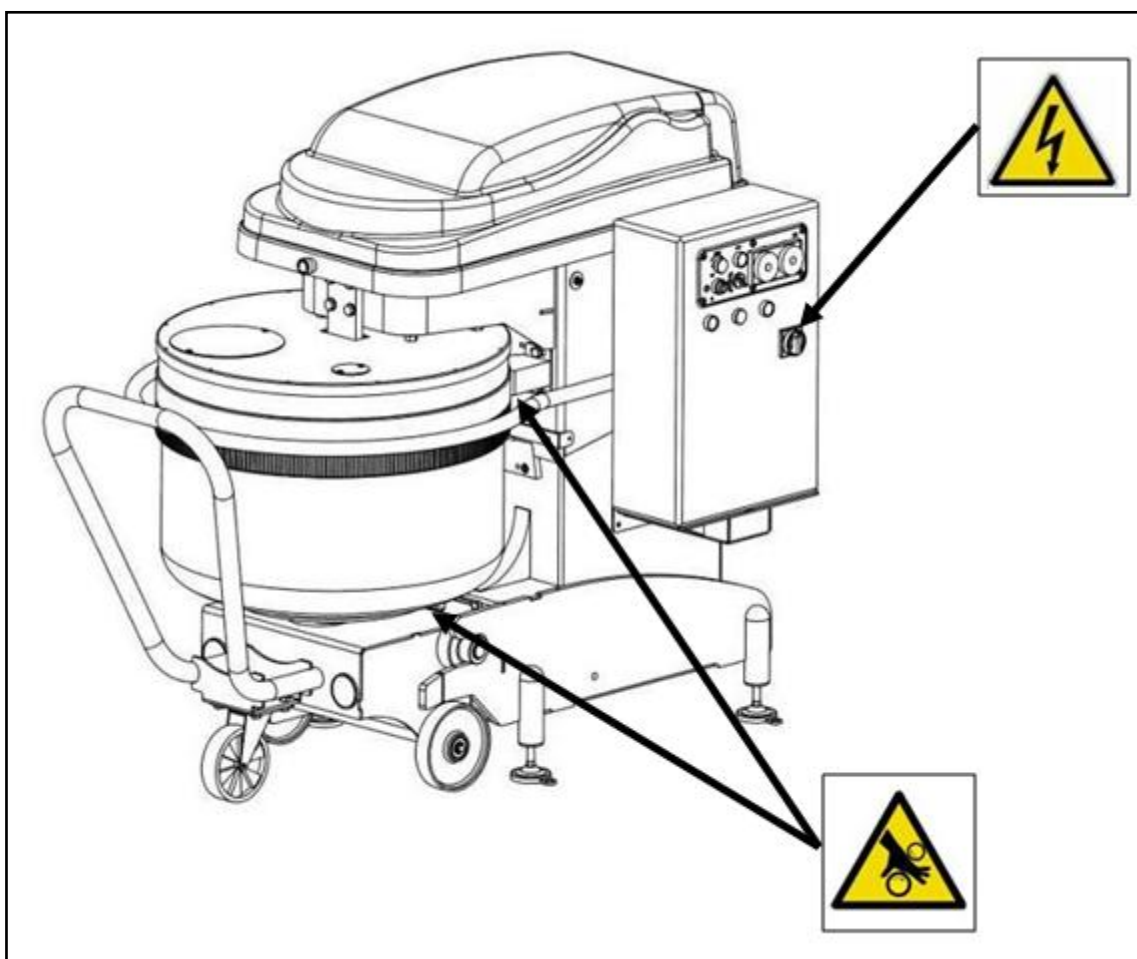

Earthing obligation



Prohibition to clean and lubricate moving parts.



Prohibition to remove the safety devices and guards

ATTENTION!

Wear the provided PPE during operation (e.g. shoes with reinforced tip, gloves, goggles and masks).

Clean the machine thoroughly after use.

Do not remove the safety devices or protective casings.

Do not put any objects through the bowl guard with the parts in motion.

Before any manoeuvre wait for the machine to completely stop, turn it off and disconnect it from the mains.



2. Machine description

MACHINE DESCRIPTION AND USE:

The SILVER VE mixing machines are designed for professional use only, to mix water and flour-based food dough for bread-making and pastry workshops. A spiral rotates mixing, refining and oxygenating the mix contained in a rotary bowl and, thanks to the vigorous mechanical action performed by the system, the mix is quickly and effectively prepared.

As specified above, the machines are for professional use only, by educated, trained and authorised personnel.

Any other use is forbidden, any particular needs and specifications must be examined by the SELLER on request.

Once the bowl on the trolley is filled with water and additives (in this order and in the amounts described later on), the trolley can be taken to its position, with the head up. The head lowers (by means of a hydraulic system) once the trolley is blocked (by means of an electro-magnetic system). Once this operation is complete, the machine can be started by means of the control panel. At this point the spiral rotates together with the bowl mixing the ingredients. To empty the bowl, stop the machine by pressing the stop button and lift the head to remove the trolley. Use a plastic spatula to remove the dough from the bowl and to prevent the latter from scratches.

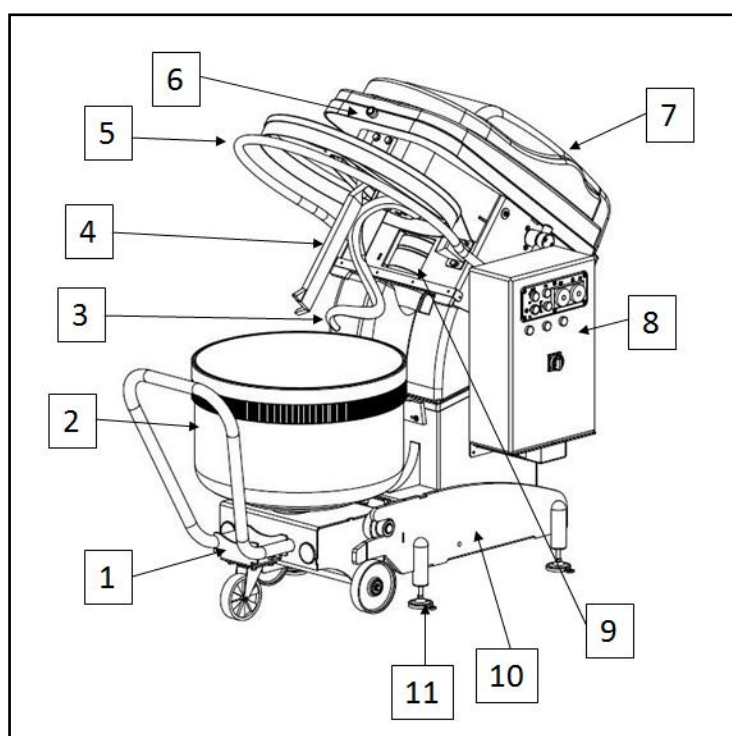

1) TROLLEY: support and transport mean of the bowl, consisting of a frame mounted on wheels.

2) BOWL: container in which the various ingredients to be mixed are inserted, is equipped with rotation;

3) SPIRAL: tool used to mix the dough, through rotational movement;

4) CONTRAST ROD: tool contrasting the spiral, to improve product mixing;

5) RING: it is used in case of emergency to lift the head during the descent phase;

6) EMERGENCY BUTTON: used to stop the machine in case of emergency;

7) HEAD: removable part of the machine;

8) CONTROL PANEL: electromechanical and/or digital device used to start or stop the machine, and set the processing time;

9) CLUTCH WHEELS: used to make the bowl rotate;

10) BEARING STRUCTURE: machine body;

11) LIFTING FEET: used as support and to stabilise the machine during operation.

3. Machine identification

There is a plate on the machine casing, like the one illustrated, which carries indications concerning the manufacturer, type of machine, serial number, electrical features, frequency, rated power, number of phases, year of manufacture and mass.

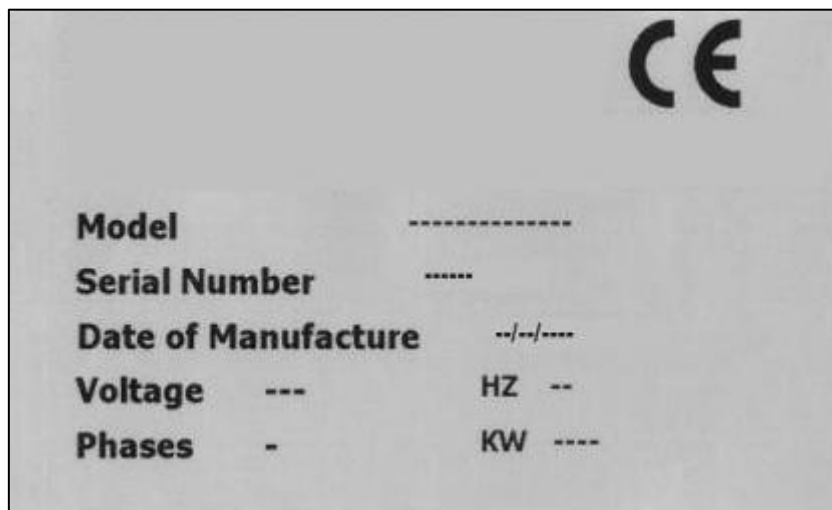

3.1. Main components

- Raw materials used: the machine is almost completely made of steel, cast iron, brass and plastic. All of these components can be easily disposed of and are not dangerous to the environment and/or a hazard to personal safety. Adequately separate the different materials for subsequent reuse or separate disposal.
- Surface treatment: paint, electrolytic galvanising, chemical nickel-plating, Teflon coating, electro polishing, to ensure high technical performance, hygiene and durability.
- The Sigma packages fully meet the requirements of Directive 94/62/EC and Legislative Decree 05/02/97 no. 22 (and subsequent amendments and additions) and so become waste similar to urban, that can be easily inserted in any separate collection program.

4. Technical data and features

4.1.1. Technical data

MODEL	MACHINE MASS [kg]	POWER [kW]	BOWL [litres]	ELECTRICAL POWER SUPPLY
SILVER VE 160	980	6/12	230	400V 50Hz 3 phases + PE
SILVER VE 200	1015	6/12	290	400V 50Hz 3 phases + PE
SILVER VE 250	1027	6/12	400	400V 50Hz 3 phases + PE
SILVER VE 300	1038	7/15	400	400V 50Hz 3 phases + PE

4.1.2. Machine dimensions

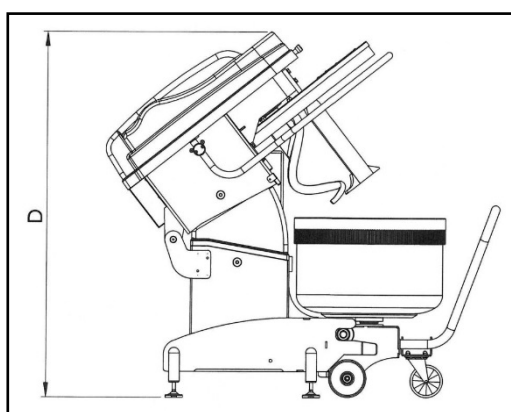
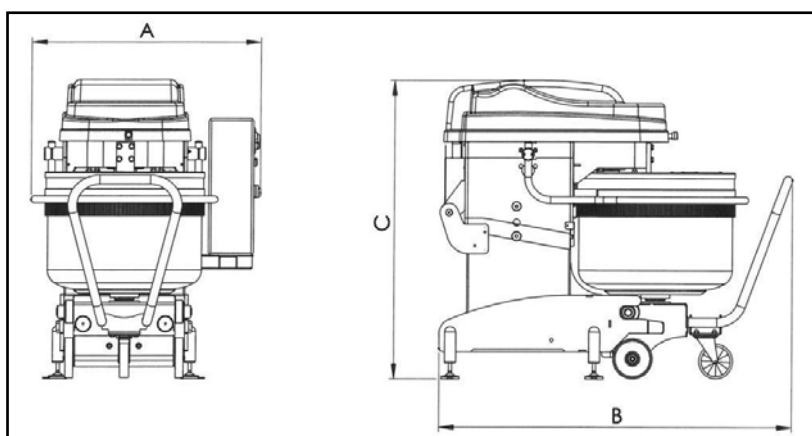

VE 160-200

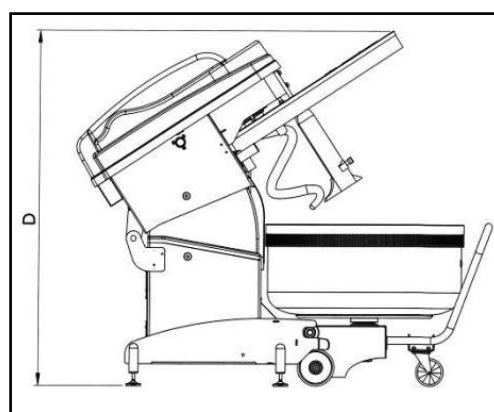

VE 250-300

MODEL	A	B	C	D
SILVER VE 160-200	1250mm	1850mm	1490mm	1890mm
SILVER VE 250-300	1350mm	2000mm	1490mm	1950mm

4.1.3. Trolley dimensions

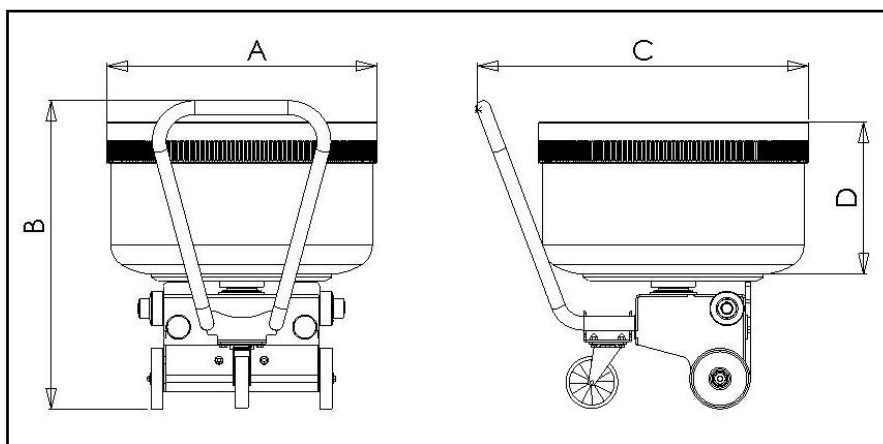

MODEL	A	B	C	D
SILVER VE 160	855mm	870mm	980mm	490mm
SILVER VE 200	910mm	870mm	1040mm	490mm
SILVER VE 250	1010mm	870mm	1190mm	490mm
SILVER VE 300	1060mm	870mm	1200mm	490mm

4.2. Control panel

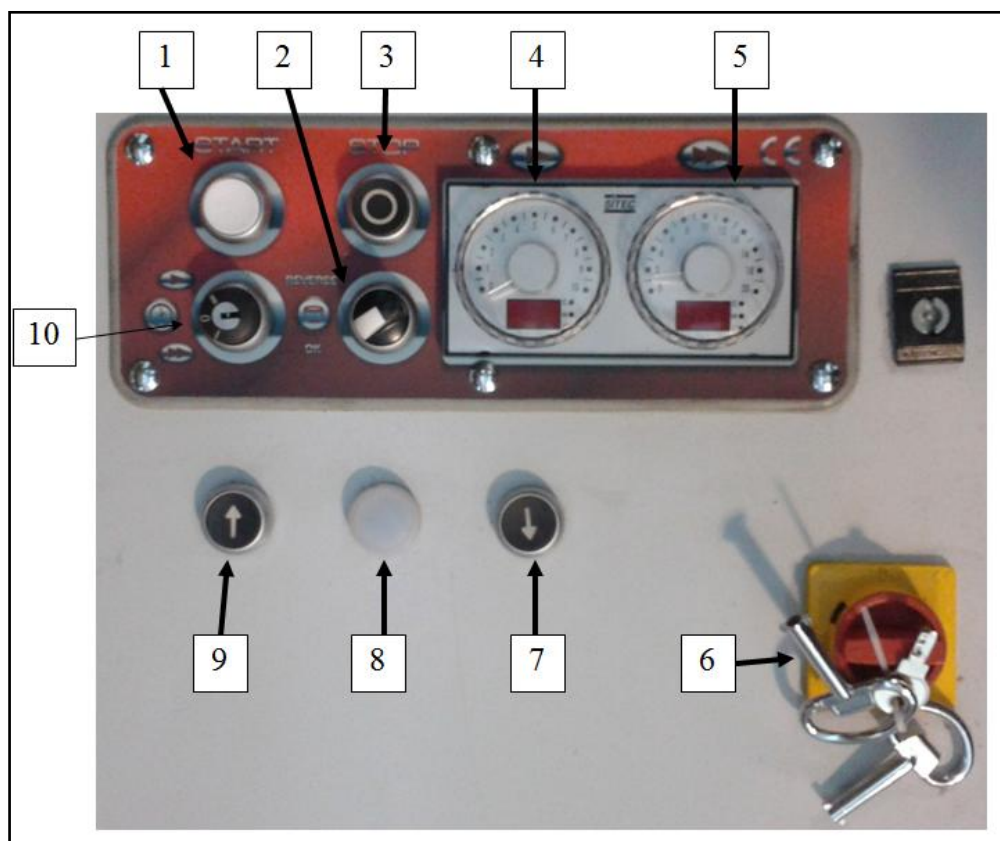

- 1) START BUTTON
- 2) BOWL ROTATION DIRECTION REVERSAL (for a limited time, ONLY in first speed)
- 3) STOP/EMERGENCY BUTTON
- 4) FIRST SPEED TIMER
- 5) SECOND SPEED TIMER
- 6) MASTER SWITCH
- 7) HEAD DESCENT
- 8) MAINS INDICATOR
- 9) HEAD ASCENT
- 10) MANUAL SELECTOR (activate in case of faulty timers, you can choose between first and second speed) **USE ONLY IF NECESSARY (the key is kept and used by a manager ONLY).**

5. Transport and installation

5.1. Transport and handling

5.1.1. Machine on pallet



Make sure that the lifting equipment capacity is adequate to the load.

Widen the lifting forks as much as possible and make sure they stick out from the pallet.

Work in an area free from persons and animals.

During movement, always keep the load as close to the ground as possible.

Use the required P.P.E. (e.g. shoes with reinforced tip).

Standards on lifting using a forklift truck: always use a pallet to move the machine.

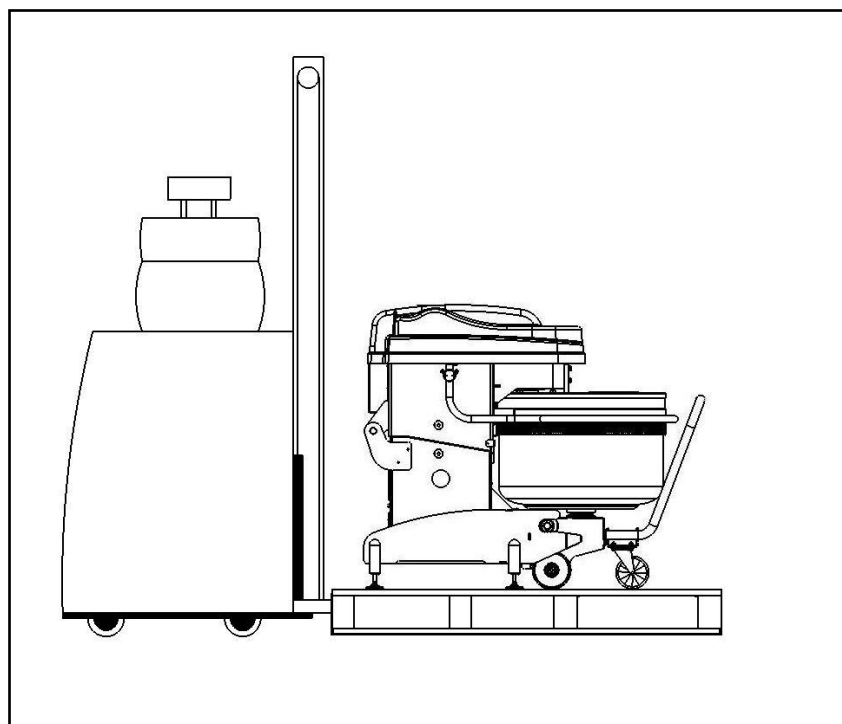

5.1.2. Machine without pallet

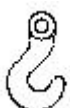

Make sure that the lifting means complies with the load.

Widen the lifting forks as much as possible and make sure they stick out from the pallet.

Make sure the lifting equipment is adequate for the load. Work in an empty area. During movement, always keep the load as close to the ground as possible.

Use the required P.P.E. (e.g. shoes with reinforced tip).

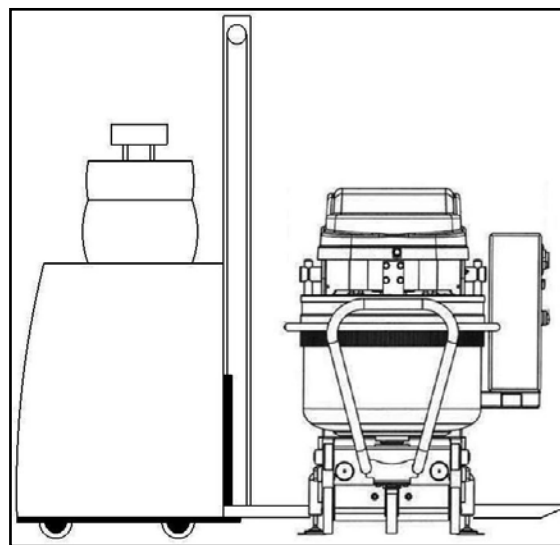
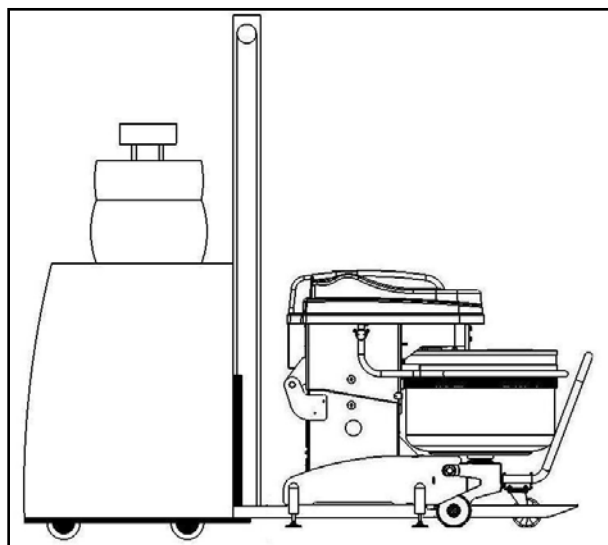

5.2. Description of the adjustment and commissioning operations

5.2.1. Installation



The machine must be positioned vertically on a smooth surface and able to support the weight (floor with resistance above 20 kg/cm²). The walls and the floor must be in good condition and easy to clean.

If there is a risk of overturning, anchor the machine to the floor using 4 wedges or bolts with tensile strength greater than 300 kg (M8) with the specific anchors that can be supplied on request.

5.2.2. Electric line connection



The electrical connection must be done by a qualified electrician, according to the methods and regulations in force in the country of installation.

The machine is supplied with power cable without plug. The cable must be kept away from hot and/or moving parts and must not obstruct the movement or transiting of people and things. The socket into which the plug will be inserted must have adequate features to the maximum current of absorption of the load and comply with the laws and regulations in force (including being correctly connected to the earthing system, which must be periodically checked by an authorised and competent technician).



Make sure that the system voltage and frequency match those on the machine identification plate, incorrect connection voids the warranty.

6. User instructions

6.1. Operating instructions



For the machine to work, the machine must be lowered and the trolley inserted, otherwise the safety systems prevent its operation. Check the correct rotation direction of the bowl (anti-clockwise, following the arrow on the bowl), if not correct contact a qualified electrician for intervention.

The machine **MUST** be used by a single operator at a time.

DO NOT REMOVE OR TAMPER WITH THE PROTECTIONS AND ELECTRICAL OR MECHANICAL SAFETY DEVICES FITTED ON THE MACHINE.

6.1.1. To start the machine

The machine is equipped with a master switch on the right side and it is controlled from the front electro-mechanical control panel (see chap. 10.2).

To work the machine, place the master switch at ON. Using the two timers, select the desired time for the first and second speeds (by turning the cap), and press start to start the dough. Press STOP to stop the machine.

6.2. Working with the machine.

The machine is now ready to mix. Follow some simple rules:

- Firstly, pour the necessary amount of water in the bowl.
- Add the correct amount of flour, the dough will gradually harden until the right consistency is obtained. On the contrary, adding water to flour creates masses of flour on the bottom that will require longer machining time with consequent dough damage.
- The other ingredients (salt, yeast, oil, etc.) are added as desired



The following table is to be considered a general indication of the factory.

For doughs with a different water percentage to that indicated, contact the manufacturer.

MODEL	DOUGH CAPACITY [kg]	WATER [%]
SILVER VE 160	116 – 160	55÷60%
SILVER VE 200	194 – 200	55÷60%
SILVER VE 250	233 – 240	55÷60%
SILVER VE 300	295 - 300	55÷60%

The use of flour rich in gluten gives rise to very elastic doughs, which absorb a lot of power. In this case, like in the case of dough with lower percentage of water to that indicated in the table, it is necessary to reduce the maximum dough capacity of the machine.

7. Maintenance and clearing

7.1. Routine maintenance

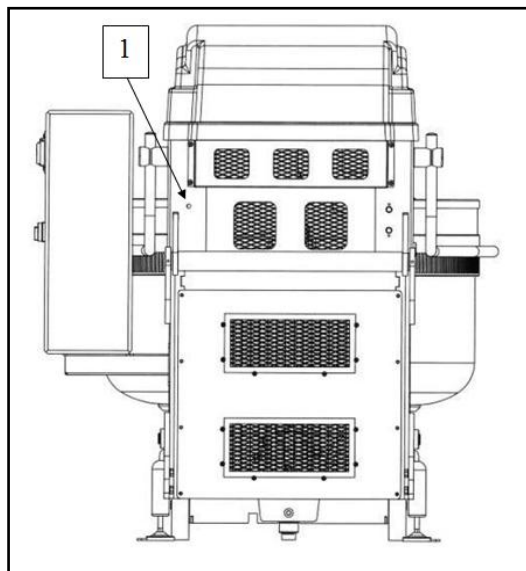

- 1) Periodically (six-monthly.) grease the machine through the specific grease nipples.
- 2) Use food grease, e.g. BECHEM BELORUB FB19, use a manual coupling grease pump.
- 3) For PPE wear shoes with reinforced tip and non-slip sole, helmet and goggles.
- 4) Carefully read the lubricant's technical data sheet and follow its instructions.

Need to provide adequate training to maintenance personnel.

7.2. Machine lock-up and necessary solutions

Operating anomalies	Possible causes	Repairs	Performed by
Turning the master switch into position 1, the indicator light does not come on.	Plug not inserted properly, or its wires are detached	Check the connection	Personnel authorised by the employer and/or qualified personnel in possession of the technical knowledge of the work.
Pressing the START button, the machine does not start.	1) The protection grid is open. 2) Safety micro switches anomalies.	1) Rotate it and reposition it in closed position. 2) Replace the micro switch.	Personnel authorised by the employer and/or qualified personnel in possession of the technical knowledge of the work.
The spiral does not rotate smoothly.	1) Loose chain or belt. 2) Worn belt.	1) Tension the chain or belt. 2) Replace the belt.	Personnel authorised by the employer and/or qualified personnel in possession of the technical knowledge of the work.
The bowl does not rotate smoothly.	1) Loose chain. 2) Worn chain.	1) Tension the chain. 2) Replace the chain.	Personnel authorised by the employer and/or qualified personnel in possession of the technical knowledge of the work.
The tool does not revolve normally on the tool carrier shaft.	1) Loose chain or belt. 2) Worn belt.	1) Tension the chain or belt. 2) Replace the belt.	Personnel authorised by the employer and/or qualified personnel in possession of the technical knowledge of the work.

7.3. Machine cleaning

Daily Checks



Always keep the machine clean to prevent the formation of micro-organism colonies that can alter the end product and be harmful to health. It is also important that flour does not deposit on moving parts, thus creating annoying squeaks and abnormal wear.

FOR ANY MAINTENANCE AND CLEANING OPERATIONS, THE MACHINE MUST BE OFF AND DISCONNECTED FROM THE ELECTRIC LINE.

Cleaning: the machine is not spray-proof; it must not be cleaned with running water or compressed air, to minimise dust movement. To vacuum the dust, use a professional vacuum equipped with adequate filters depending on the grain size of the flour.

Cleaning the bowl: use a damp cloth and/or PLASTIC spatulas with water only.

N.B.: it is not advisable to use metal spatulas to clean the bowl.

Cleaning the column and spiral: use a damp cloth with water only. Mop between the bowl and column and/or between the bowl and spiral to avoid the formation of contaminated areas



Warranty

The Univex spiral mixer carries a One-Year, on-site, parts and labor warranty against any defects in materials or workmanship.

The one-year period begins on the date of purchase by the end user and remains in full effect provided the unit is used properly and in accordance with our operators manual.

Any work to be performed under this warranty must be performed between the hours of 8:00 a.m. and 5:00 p.m. local time, Monday through Friday. Univex will not cover overtime charges of any kind.

Please call the Univex Warranty Service Department at (800) 258-6358 or (603) 893-6191 to report any warranty claims before arranging repair or attempting to return the unit to Univex Corporation.

Damages incurred in transit or incurred because of installation error, accident, alteration or misuse are not covered. Transit damages should be reported to the carrier immediately.

Univex will not be liable for any consequential, compensatory, incidental or special damages.